

YASKAWA

MOTOMAN GP Series

Handling & General Application



Controlled by
YRC1000

Controlled by
YRC1000
micro

MOTOMAN GP8



reddot award 2018
winner

Masters of Robotics, Motion and Control

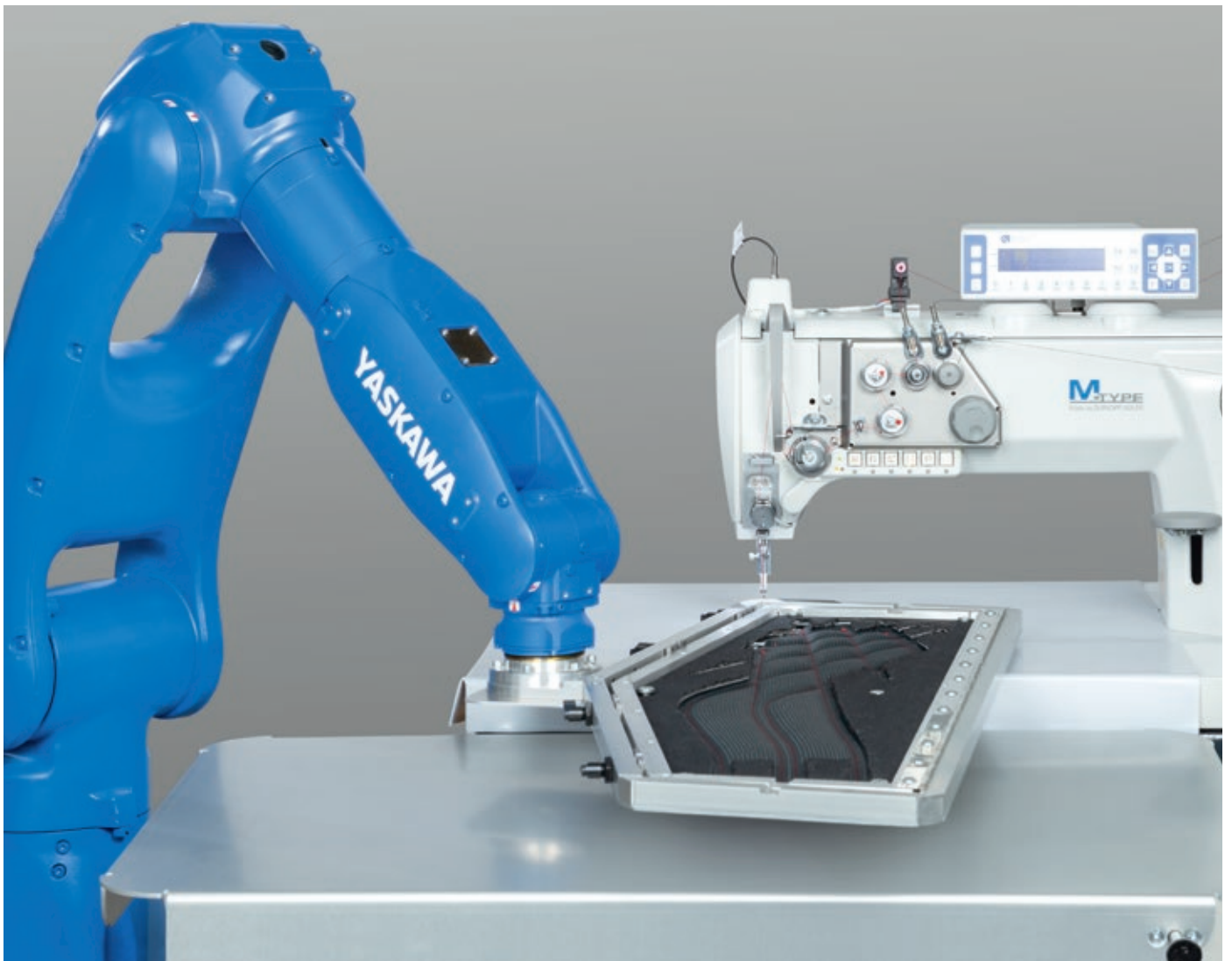

Contents

MOTOMAN GP Series

Overview	4
GP4.....	7
GP7.....	9
GP8	11
GP8L	13
GP10	15
GP12	17
GP20	19
GP20HL.....	21
GP25	23
GP25-12	25
GP35L	27
GP35H	29
GP50	31
GP70L	33
GP88	35
GP110	37
GP180-120	39
GP180	41
GP215	43
GP215-200T	45
GP225	47
GP250	49
GG250	51
GP280	53
GP280L	55
GP360	57
GP400	59
GP600	61

Controller

YRC1000	65
YRC1000micro	69
Smart Pendant	73

Energy recovery	76
-----------------------	----

Overview

GP4



Max. payload:
4 kg
Repeatability:
±0,01 mm
Max. working range R:
550 mm
Weight:
28 kg

GP7



Max. payload:
7 kg
Repeatability:
±0,01 mm
Max. working range R:
927 mm
Weight:
37 kg

GP8



Max. payload:
8 kg
Repeatability:
±0,01 mm
Max. working range R:
727 mm
Weight:
35 kg

GP8L



Max. payload:
8 kg
Repeatability:
±0,02 mm
Max. working range R:
1636 mm
Weight:
155 kg

GP10



Max. payload:
10 kg
Repeatability:
±0,015 mm
Max. working range R:
1101 mm
Weight:
59 kg

GP12



Max. payload:
12 kg
Repeatability:
±0,02 mm
Max. working range R:
1440 mm
Weight:
150 kg

GP20



Max. payload:
20 kg
Repeatability:
±0,02 mm
Max. working range R:
1802 mm
Weight:
250 kg

GP20HL



Max. payload:
20 kg
Repeatability:
±0,07 mm
Max. working range R:
3124 mm
Weight:
560 kg

GP25



Max. payload:
25 kg
Repeatability:
±0,02 mm
Max. working range R:
1730 mm
Weight:
250 kg

GP25-12



Max. payload:
12 kg
Repeatability:
±0,03 mm
Max. working range R:
2010 mm
Weight:
260 kg

GP35L



Max. payload:
35 kg
Repeatability:
±0,07 mm
Max. working range R:
2538 mm
Weight:
600 kg

GP35H



Max. payload:
35 kg
Repeatability:
±0,07 mm
Max. working range R:
2070 mm
Weight:
545 kg

GP50



Max. payload:
50 kg
Repeatability:
±0,03 mm
Max. working range R:
2061 mm
Weight:
570 kg

GP70L



Max. payload:
70 kg
Repeatability:
±0,05 mm
Max. working range R:
2732 mm
Weight:
650 kg

GP88



Max. payload:
88 kg
Repeatability:
±0,03 mm
Max. working range R:
2236 mm
Weight:
630 kg

GP110



Max. payload:
110 kg
Repeatability:
 $\pm 0,03$ mm
Max. working range R:
2236 mm
Weight:
660 kg

GP180-120



Max. payload:
120 kg
Repeatability:
 $\pm 0,05$ mm
Max. working range R:
3058 mm
Weight:
1090 kg

GP180



Max. payload:
180 kg
Repeatability:
 $\pm 0,05$ mm
Max. working range R:
2702 mm
Weight:
1020 kg

GP215



Max. payload:
215 kg
Repeatability:
 $\pm 0,05$ mm
Max. working range R:
2912 mm
Weight:
1340 kg

GP215-200T



Max. payload:
200 kg
Repeatability:
 $\pm 0,05$ mm
Max. working range R:
2676 mm
Weight:
1360 kg

GP225



Max. payload:
225 kg
Repeatability:
 $\pm 0,05$ mm
Max. working range R:
2702 mm
Weight:
1080 kg

GP250



Max. payload:
250 kg
Repeatability:
 $\pm 0,05$ mm
Max. working range R:
2710 mm
Weight:
1345 kg

GG250



Max. payload:
250 kg
Repeatability:
 $\pm 0,025$ mm
Max. working range R:
2711 mm
Weight:
1640 kg

GP280



Max. payload:
280 kg
Repeatability:
 $\pm 0,05$ mm
Max. working range R:
2446 mm
Weight:
1300 kg

GP280L



Max. payload:
280 kg
Repeatability:
 $\pm 0,1$ mm
Max. working range R:
3114 mm
Weight:
2390 kg

GP360



Max. payload:
360 kg
Repeatability:
 $\pm 0,1$ mm
Max. working range R:
2832 mm
Weight:
2380 kg

GP400



Max. payload:
400 kg
Repeatability:
 $\pm 0,1$ mm
Max. working range R:
2942 mm
Weight:
2840 kg

GP600



Max. payload:
600 kg
Repeatability:
 $\pm 0,1$ mm
Max. working range R:
2942 mm
Weight:
3035 kg



YASKAWA

YASKAWA

YASKAWA

YASKAWA

YASKAWA

MOTOMAN GP4

Handling & General Applications
with the GP Series



The MOTOMAN GP4 is the smallest 6-axis robot in Yaskawa's GP Series model range and offers high performance for a wide range of applications, such as flexible handling, machine tending and assembly applications, with a payload of up to 4 kg. Providing an outstanding repeatability of ± 0.01 mm, it is ideally suited for use in the electronics sector as well as for high precision assembly and quality testing applications.

But more than this, the MOTOMAN GP4 is extremely agile and fast – with axis speeds of up to 1000 %/s.

The high IP67 protection class allows it to be used for CNC machine tending even under harsh environmental conditions, and its small footprint and compact design allows installation even in the tightest spaces. Thanks to the integrated media and air supply, installation of grippers or sensors is easy.

The MOTOMAN GP4 is available with the YRC1000 or the YRC1000micro controller. Customers can select between the classical teach pendant or the innovative Smart Pendant for operation and programming. The optional MotoLogix interface allows full integration into PLC Programming Environment.

In terms of connectivity – I/O, Fieldbus, IoT, conveyors, machine vision and other sensors, the MOTOMAN GP4 benefits from all the versatile features, tools and options of the compact Yaskawa standard robot controller.

KEY BENEFITS

- High Motion Speed: up to 1000 %/s per axis
- Flexible mounting options: Floor, tilt, wall, ceiling
- Operation in confined spaces:
 - Compact design
 - Small footprint
- Payload: up to 4 kg
- Outstanding repeatability: ± 0.01 mm
- High protection class and easy cleaning: IP67

Controlled by
YRC1000

Controlled by
**YRC1000
micro**

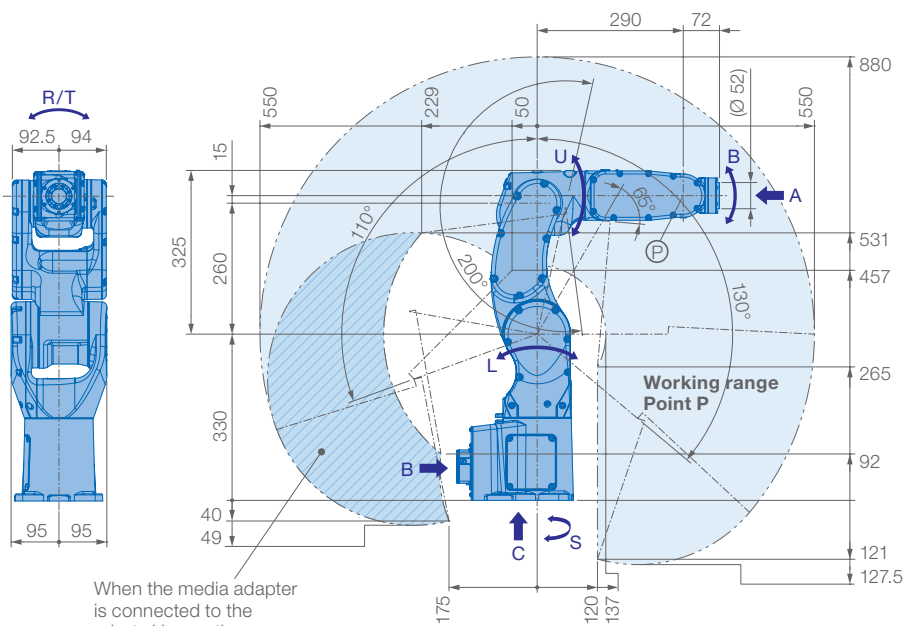

When the media adapter is connected to the robots U-arm, the working range is limited according to the hatching area.

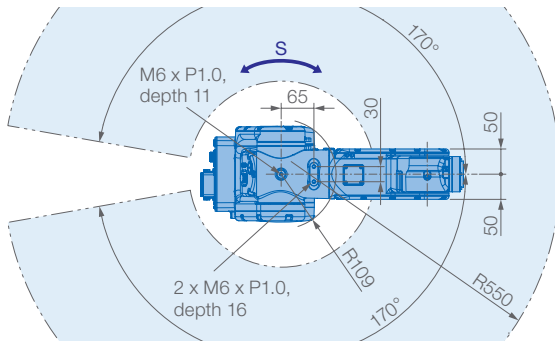

Prevent interaction of the robot with:

- Corrosive gases, liquids or explosive gases
- Exposure to water, oil or dust
- Excessive electrical noise (plasma)

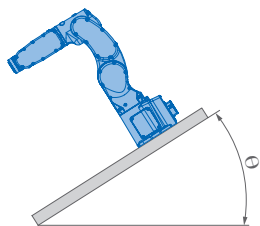

Allowable wrist load

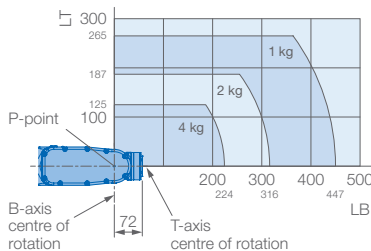

View A

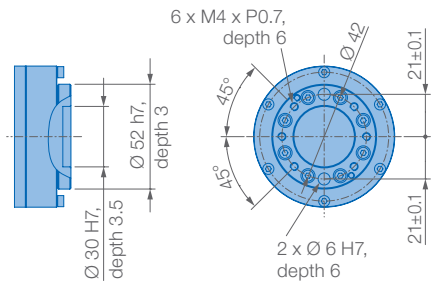

View B

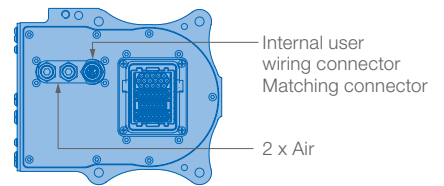

View C

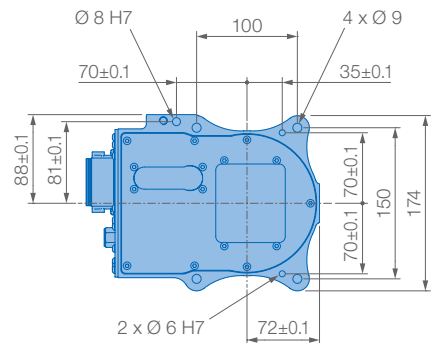

Mounting options: Floor, ceiling, wall, tilt
 Protection class version YR-1-06VX4-A00 standard: IP67
 Option: Version YR-1-06VX4-F00 (FGG)
 Tilt angle without limitations
 No operating limit in S-axis

Specifications GP4					
Axes	Maximum motion range [°]	Maximum speed [°/s]	Allowable moment [Nm]	Allowable moment of inertia [kg · m ²]	Controlled axes
S	±170	465	-	-	6
L	+130/-110	465	-	-	Max. payload [kg]
U	+200/-65	525	-	-	Repeatability [mm]
R	±200	565	8.86	0.2	Max. working range R [mm]
B	±123	565	8.86	0.2	Temperature [°C]
T	±455	1000	4.9	0.07	Humidity [%]
					Weight [kg]
					Power supply, average [kVA]

MOTOMAN GP7

Handling & General Applications
with the GP Series



The MOTOMAN GP7 is an extremely fast and precise 6-axis industrial robot with a payload capacity of up to 7 kg. With a reach of 927 mm and a high repeatability of ± 0.01 mm, it is ideally suited to assembly tasks, but also universal handling tasks, CNC machine tool tending or packaging. Its smooth and streamlined modern industrial design is attractive and minimizes the space requirements at the installation site.

Cable entry is optionally from the side at the pedestal or from underneath through the base plate, thus enabling space-saving and uncluttered integration into its environment, irrespective of the intended installation position. The prepared routing of the supply lines in the arm enables optimal integration of the grippers or sensor systems, often dispensing with the need for an external media package.

A world of possibilities is open to the MOTOMAN GP7 with the numerous functions of the MOTOMAN YRC1000 controller or the compact MOTOMAN YRC1000micro controller. In conjunction with the conventional teach pendant, this robot is a reliable mechanical engineering partner. With the innovative operator control concept of the SmartPendant, it provides an excellent point of entry into the world of robotics.

As standard, the MOTOMAN GP7 is designed with the high protection classification IP67. Other variants (e.g. with food-compatible grease in the food industry, special anti-corrosion coating for applications in aggressive ambient conditions, or as a cleanroom version CR5) are optionally available.

KEY BENEFITS

- Extremely fast and powerful
- Compact and flexible
- Large working range: 927 mm
- Reduced interference contours due to optimized design
- Simple commissioning and maintenance

Controlled by
YRC1000

Controlled by
**YRC1000
micro**

MOTOMAN GP8

Handling & General Applications
with the GP Series



The MOTOMAN GP8 is an extremely fast and precise 6-axis industrial robot with a payload capacity of up to 8 kg. With a reach of 727 mm and a high repeatability of ± 0.01 mm, it is ideally suited to assembly tasks, but also universal handling tasks, CNC machine tool tending or packaging. Its smooth, streamlined and award-winning modern industrial design is attractive and minimizes the space requirements at the installation site.

Cable entry is optionally from the side at the pedestal or from underneath through the base plate, thus enabling space-saving and uncluttered integration into its environment, irrespective of the intended installation position. The prepared routing of the supply lines in the arm enables optimal integration of the grippers or sensor systems, often dispensing with the need for an external media package.

A world of possibilities is open to the MOTOMAN GP8 with the numerous functions of the MOTOMAN YRC1000 controller or the compact MOTOMAN YRC1000micro controller. In conjunction with the conventional teach pendant, this robot is a reliable mechanical engineering partner. With the innovative operator control concept of the SmartPendant, it provides an excellent point of entry into the world of robotics.

As standard, the MOTOMAN GP8 is designed with the high protection classification IP67. Other variants (e.g. with food-compatible grease in the food industry, special anti-corrosion coating for applications in aggressive ambient conditions, or as a cleanroom version CR5) are optionally available.

KEY BENEFITS

- Extremely fast and powerful
- Compact and flexible
- Large working range: 727 mm
- Reduced interference contours due to optimized design
- Simple commissioning and maintenance



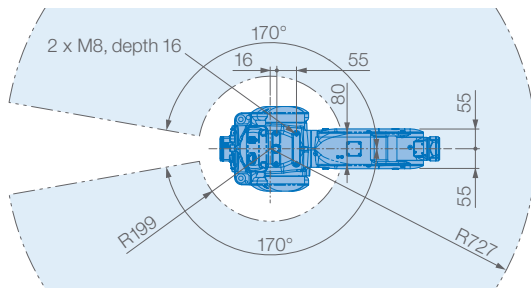
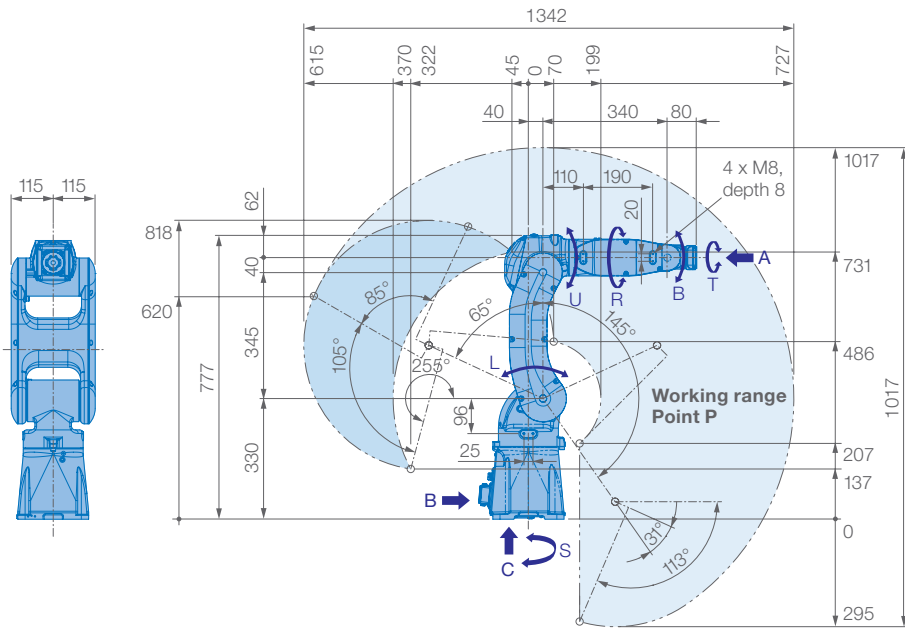

Allowable wrist load

Prevent interaction of the robot with:

- Corrosive gases, liquids or explosive gases
- Exposure to water, oil or dust
- Excessive electrical noise (plasma)

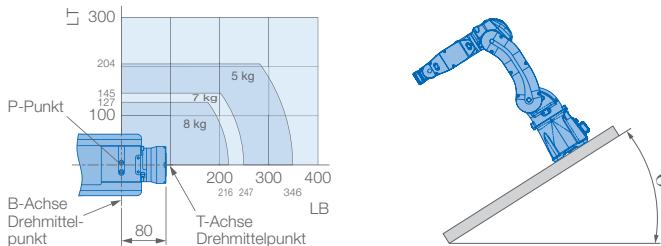

View A

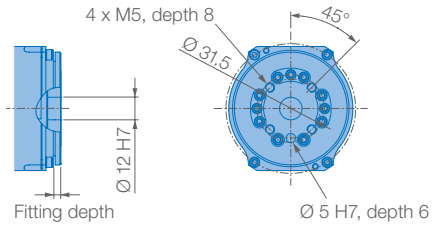

View B

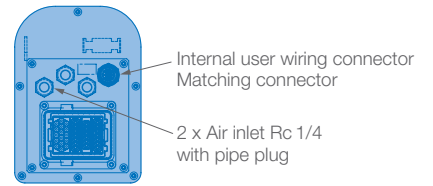

View C

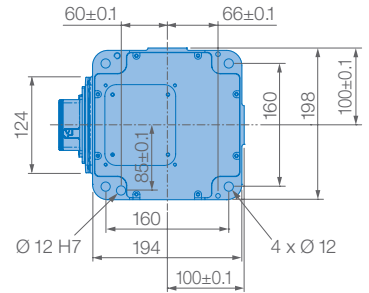

Mounting options: Floor, ceiling, wall, tilt*

IP Protection: IP67

Option: Cleanroom class 5

* tilt with condition of angle – see table below

Robot installation angle θ [deg.]	S-axis operating range [deg.]
$0 \leq \theta \leq 30$	± 170 max. no limit
$30 < \theta \leq 35$	± 60 max.
$35 < \theta \leq 45$	± 45 max.
$45 < \theta$	± 30 max.

Specifications GP8						
Axes	Maximum motion range [°]	Maximum speed [°/s]	Allowable moment [Nm]	Allowable moment of inertia [kg · m ²]	Controlled axes	
S	± 170	455	–	–	Max. payload [kg]	6
L	+145/–65	385	–	–	Repeatability [mm]	8
U	+190/–70	520	–	–	Max. working range R [mm]	$\pm 0.01^*$
R	± 190	550	17	0.5	Temperature [°C]	0 to +45
B	± 135	550	17	0.5	Humidity [%]	20 – 80
T	± 360	1000	10	0.2	Weight [kg]	35
					Power supply, average [kVA]	1**

* Conforms to ISO 9283 ** Varies in accordance with applications and motion patterns Note: SI units are used for specifications.

MOTOMAN GP8L

Handling & General Applications
with the GP Series



The 6-axis MOTOMAN GP8L is a fast, general-purpose industrial robot with 8 kg payload and a long reach of 1,636 mm.

With its slim design and compact, very narrow wrist, it is particularly suitable for applications where space is at a premium, such as loading/unloading containers in packaging technology or logistics. Automation around machine tools and injection molding machines can also be excellently implemented with this robot.

Its intelligent Yaskawa Sigma-7 drive technology enables fast cycle times with high repeatability of ± 0.02 mm.

With numerous functions, interfaces and communication options of the YRC1000/YRC1000micro controllers, the MOTOMAN GP8L is open to a full range of different technologies, including modern sensor systems and image processing systems, which can be combined very well with this robot. Alternatively, the proven MOTOMAN teach pendant or the innovative Smart Pendant for newcomers to industrial automation are available for programming.

KEY BENEFITS

- Universal use
- Fast cycle times
- Compact design and slim wrist
- Long reach: 1,636 mm
- Internal media guide
- Easy installation, commissioning and operation

Controlled by
YRC1000

Controlled by
YRC1000
micro

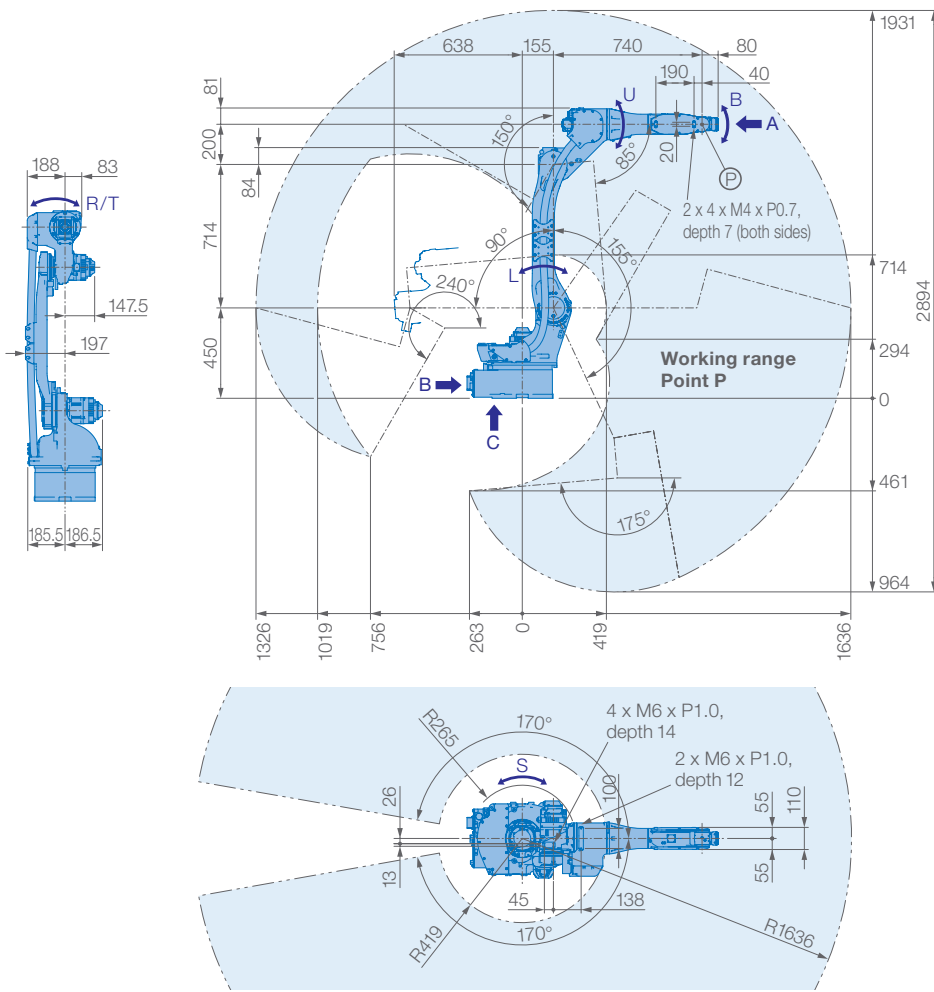

View A

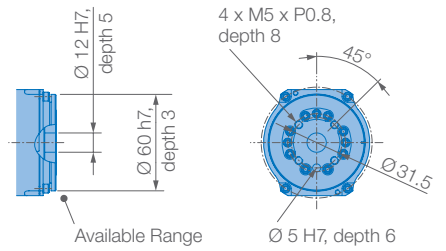

View B

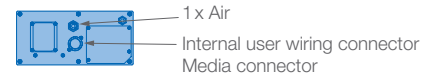

View C

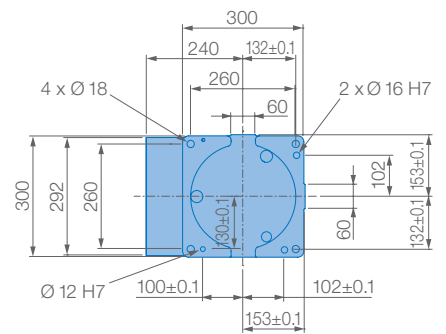

Mounting options: Floor, ceiling, wall, tilt*

IP Protection: Main axes (S, L, U) IP54, wrist IP67

* tilt with condition of angle – see table below

Allowable wrist load

Prevent interaction of the robot with:

- Corrosive gases, liquids or explosive gases
- Exposure to water, oil or dust
- Excessive electrical noise (plasma)

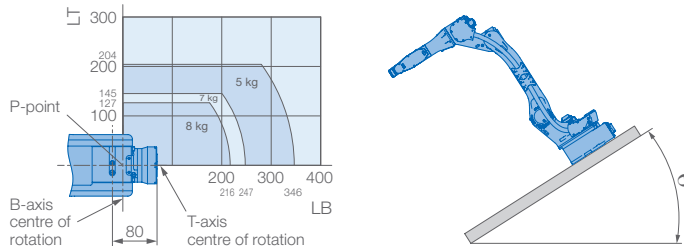

Robot installation angle θ [deg.]	S-axis operating range [deg.]
$0 \leq \theta \leq 30$	± 170 max. no limit
$30 < \theta \leq 35$	± 60 max.
$35 < \theta \leq 45$	± 45 max.
$45 < \theta$	± 30 max.

Specifications GP8L						
Axes	Maximum motion range [°]	Maximum speed [°/s]	Allowable moment [Nm]	Allowable moment of inertia [kg · m ²]	Controlled axes	6
S	± 170	260	–	–	Max. payload [kg]	8
L	+155/–90	230	–	–	Repeatability [mm]	$\pm 0.02^*$
U	+150/–85	260	–	–	Max. working range R [mm]	1636
R	± 200	470	17	0.5	Temperature [°C]	0 to +45
B	± 135	550	17	0.5	Humidity [%]	20 – 80
T	± 360	1000	10	0.2	Weight [kg]	155
					Power supply, average [kVA]	1.5**

* Conforms to ISO 9283 ** Varies in accordance with applications and motion patterns **Note:** SI units are used for specifications.

MOTOMAN GP10

Handling & General Applications
with the GP Series



The MOTOMAN GP10 is a fast and extremely precise 6-axis industrial robot with a payload capacity of up to 10 kg. With a reach of 1,101 mm and high repeatability of ± 0.015 mm, it is ideally suited to assembly tasks, but also universal handling tasks, CNC machine tool tending or packaging. Its slim, lightweight design with different mounting options makes this robot perfect for confined workspaces.

With a built-in Ethernet cable (Cat6A compatible) as standard, it can be used for a wide range of applications. Modern End-of-Arm tools such as intelligent grippers and cameras can be directly connected without the need of an external media package.

A world of possibilities is open to the MOTOMAN GP10 with the numerous functions of the MOTOMAN YRC1000 controller or the compact MOTOMAN YRC1000micro controller. While the Smart Pendant is the ideal way for beginners to work with the robot, the classical teach pendant offers wide programming options for experts.

The entire manipulator is designed with IP67 as standard, making it robust and reliable for applications even in harsh production environments.

Further specifications with anti-corrosive coat as well as built-in force sensor cable are available optionally.

KEY BENEFITS

- Powerful motion performance with new high-inertia servo drive design
- Compact, small footprint and slim arm design
- Built-in media cables to reduce interference contours
- Easy commissioning and maintenance
- IP67 protection of all axes
- Suitable for a wide variety of applications

Controlled by
YRC1000

Controlled by
**YRC1000
micro**

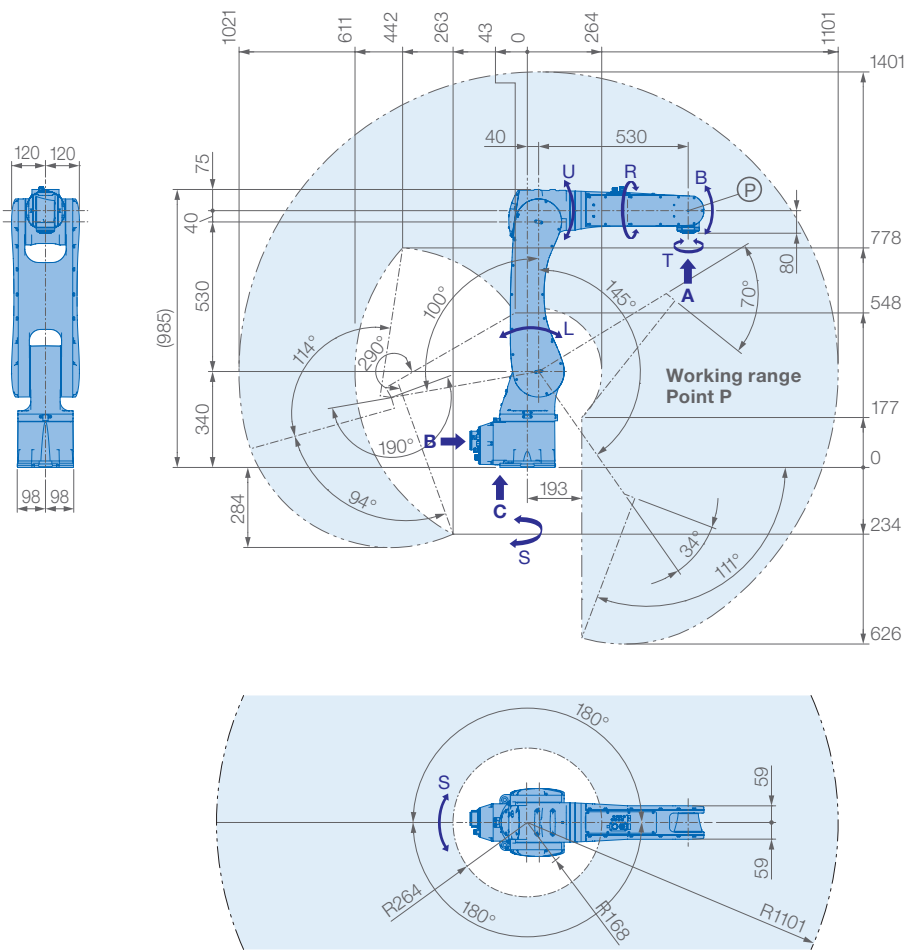

Allowable wrist load

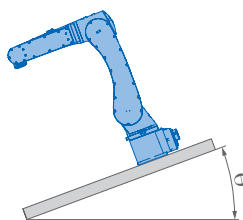
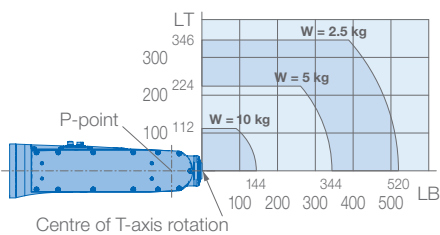

View A

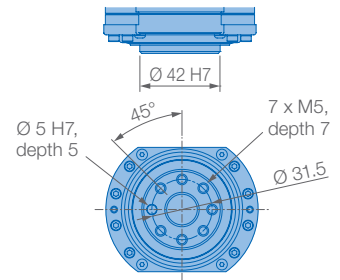

View B

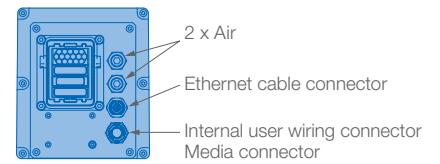

View C

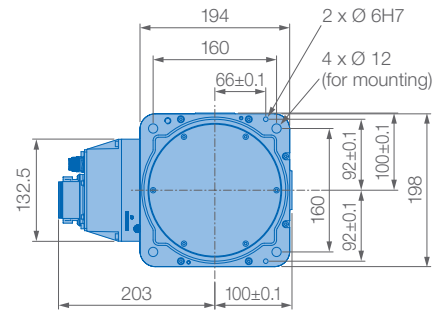

Mounting options: Floor, ceiling, wall, tilt*

IP Protection: IP67 (all axes)

* Limitations apply – see table below

Robot inclination angle θ [deg.]	S-axis operating range [deg.]
$0 \leq \theta \leq 30$	± 180 max.
$30 < \theta \leq 35$	± 60 max.
$35 < \theta \leq 45$	± 45 max.
$45 < \theta$	± 30 max.

Specifications GP10

Axes	Maximum motion range [°]	Maximum speed [°/s]	Allowable moment [Nm]	Allowable moment of inertia [kg · m ²]	Controlled axes	6
S	± 180	300	–	–	Max. payload [kg]	10
L	$+145/-100$	250	–	–	Repeatability [mm]	$\pm 0,015$
U	$+190/-70$	340	–	–	Max. working range R [mm]	1101
R	± 190	500	22	0.9	Temperature [°C]	0 to +45
B	$+225/-45$	470	22	0.9	Humidity [%]	20 – 80
T	± 360	800	11	0.3	Weight [kg]	59
					Power supply, average [kVA]	1

MOTOMAN GP12

Handling & General Applications
with the GP Series



The MOTOMAN GP12 is a fast and precise 6-axis industrial robot with a payload capacity of up to 12 kg. With a reach of 1440 mm and a high repeatability of ± 0.02 mm, it is ideally suited to assembly tasks, but also universal handling tasks, CNC machine tool tending or packaging. Its streamlined modern industrial design minimizes the space requirements at the installation site.

The prepared routing of the supply lines through the hollow arm enables optimal integration of the grippers or sensor systems, often dispensing with the need for an external media package. This reduces also interference contours.

With the MOTOMAN GP12 and numerous functions of the MOTOMAN YRC1000 controller or the compact MOTOMAN YRC1000 micro controller a wide range of applications can be realized. In conjunction with the conventional teach pendant, this robot is a reliable mechanical engineering partner. With the innovative operator control concept of the Smart Pendant, it provides an excellent point of entry into industrial automation.

As standard, the MOTOMAN GP12 is designed with the high protection classification IP67 (wrist). Other variants (e.g. with food-compatible grease in the food industry, special anti-corrosion coating for applications in aggressive ambient conditions, or as a cleanroom version) are optionally available.

KEY BENEFITS

- Fast and powerful
- Compact and flexible
- Large working range: 1440 mm
- Reduced interference contours due to optimized design
- Simple commissioning and maintenance

Controlled by
YRC1000

Controlled by
**YRC1000
micro**

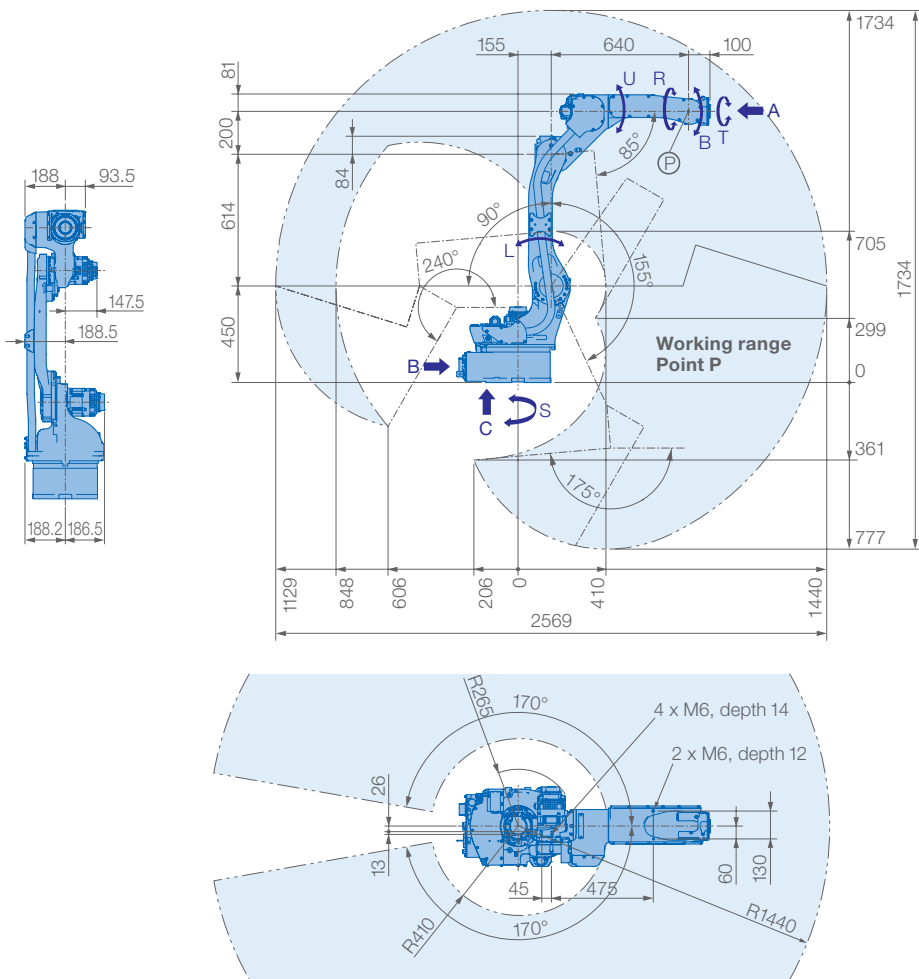

Allowable wrist load

Prevent interaction of the robot with:

- Corrosive gases, liquids or explosive gases
- Exposure to water, oil or dust
- Excessive electrical noise (plasma)

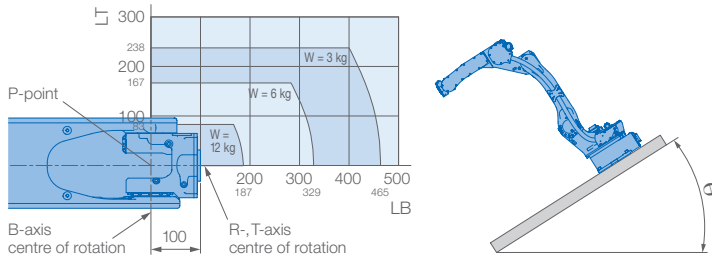

View A

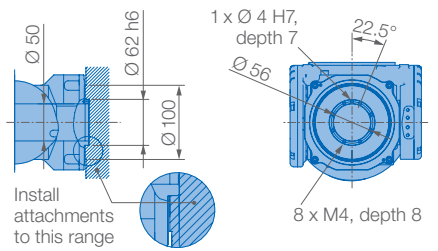

View B

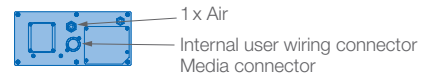

View C

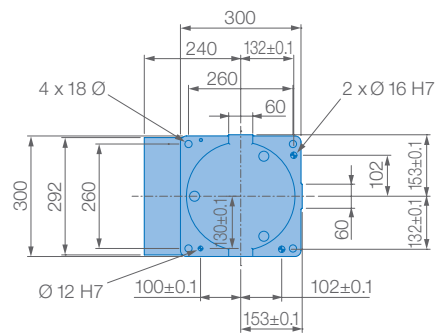

Mounting options: Floor, ceiling, wall, tilt*

Protection class Version YR-1-06VX12-A00
Standard: Main axes (S, L, U) IP54, wrist IP67

Protection class version YR-1-06VX12-C00:
Main axes (S, L, U) IP65, wrist IP67

* tilt with condition of angle – see table below

Robot installation angle θ [deg.]	S-axis operating range [deg.]
$0 \leq \theta \leq 30$	± 170 max. no limit
$30 < \theta \leq 35$	± 60 max.
$35 < \theta \leq 45$	± 45 max.
$45 < \theta$	± 30 max.

Specifications GP12					
Axes	Maximum motion range [°]	Maximum speed [°/s]	Allowable moment [Nm]	Allowable moment of inertia [kg · m ²]	Controlled axes
S	± 170	260	–	–	6
L	+155/–90	230	–	–	Max. payload [kg]
U	+155/–85	260	–	–	Repeatability [mm]
R	± 200	470	22	0.65	Max. working range R [mm]
B	± 150	470	22	0.65	Temperature [°C]
T	± 455	700	9.8	0.17	Humidity [%]
					Weight [kg]
					Power supply, average [kVA]

* Conforms to ISO 9283 ** Varies in accordance with applications and motion patterns **Note:** SI units are used for specifications.

MOTOMAN GP20

Handling & General Applications
with the GP Series



The MOTOMAN GP20 is a very versatile 6-axis industrial robot for payloads up to 20 kg. It has a reach of 1,802 mm and can achieve very fast cycle times with excellent repeatability.

The slim design, especially of the wrist allows the use in many applications, e.g. workpiece handling or machine loading/unloading. Due to its stable and IP67 protected wrist, the GP20 is also very well suited for machining or grinding operations.

Combined with the proven Teach pendant, the robot can be perfectly integrated in automation environments. With the innovative operating concept of the SmartPendant, it offers a very good entry into industrial automation.

KEY BENEFITS

- Slim design
- Versatile – large range of potential applications
- Powerful: 20 kg payload
- Large working range: 1,802 mm
- Stable, low-vibration wrist
- Fast movements due to high axis speeds and acceleration
- Easy commissioning, operation and maintenance

Controlled by
YRC1000

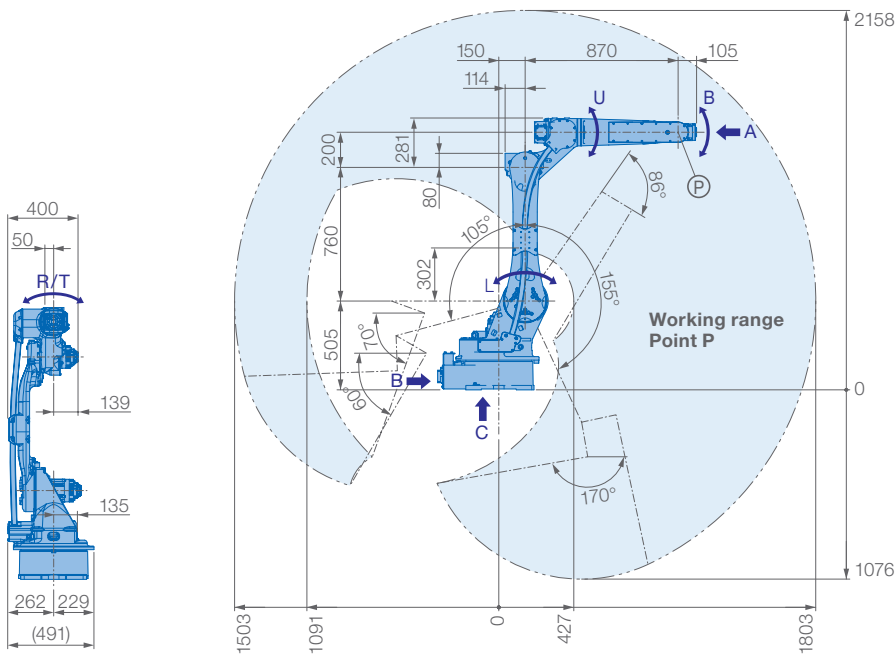

View A

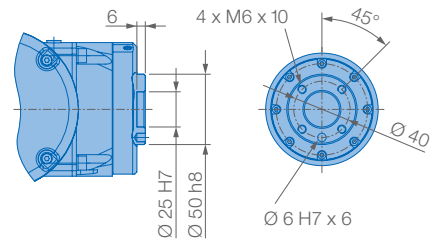

View B

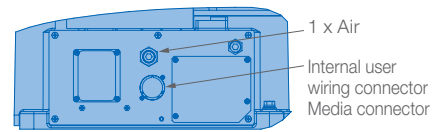

View C

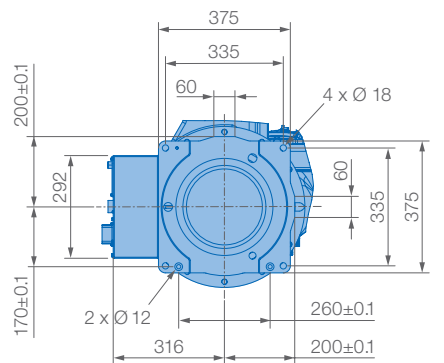

Mounting options: Floor, ceiling, wall, tilt*

IP Protection: IP54 (body S, L, U), IP67 (wrist)

* tilt with condition of angle – see table left side

Prevent interaction of the robot with:

- Corrosive gases, liquids or explosive gases
- Exposure to water, oil or dust
- Excessive electrical noise (plasma)

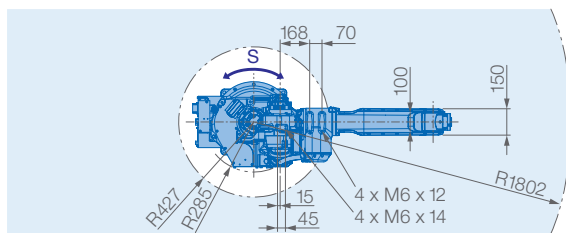

Allowable wrist load

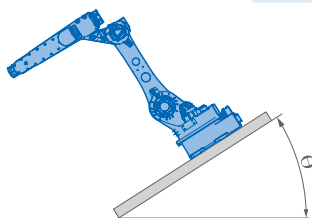
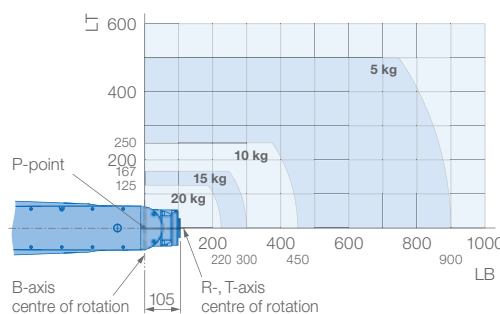

Robot installation angle θ [deg.]	S-axis operating range [deg.]
$0 \leq \theta \leq 30$	± 180 max. no limit
$30 < \theta \leq 35$	± 60 max.
$35 < \theta$	± 30 max.

Specifications GP20					
Axes	Maximum motion range [°]	Maximum speed [°/s]	Allowable moment [Nm]	Allowable moment of inertia [kg · m ²]	Controlled axes
S	± 180	210	–	–	6
L	+155/–105	210	–	–	Max. payload [kg]
U	+160/–86	265	–	–	20
R	± 200	420	44	2.3	Repeatability [mm]
B	± 140	420	44	2.3	± 0.02
T	± 455	720	24.5	1.2	Max. working range R [mm]
					1802
					Temperature [°C]
					0 to +45
					Humidity [%]
					20 – 80
					Weight [kg]
					250
					Power supply, average [kVA]
					2.0

MOTOMAN GP20HL

Handling & General Applications
with the GP Series

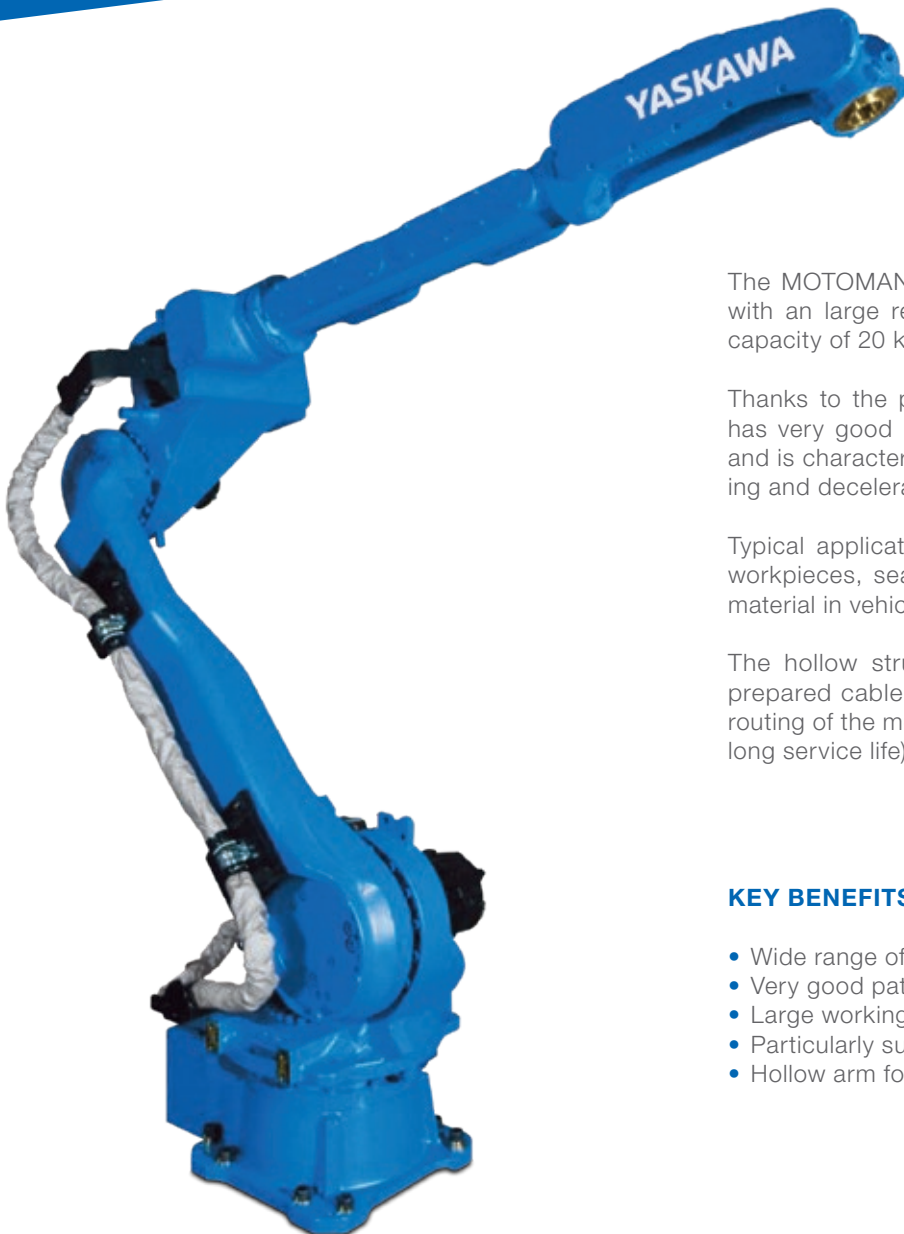

The MOTOMAN GP20HL is a universally deployable robot with a large reach of 3,124 mm and a maximum payload capacity of 20 kg.

Thanks to the patented vibration control system, this robot has very good positioning accuracy and path performance, and is characterized by almost no oscillation when accelerating and decelerating in the fully extended position.

Typical applications for this robot is handling of very large workpieces, seam sealing, and the application of insulating material in vehicle body production.

The hollow structure of the wrist joint and a number of prepared cable and hose guides in the arm enable optimal routing of the media supply lines (high freedom of motion and long service life).

KEY BENEFITS

- Wide range of potential applications
- Very good path performance
- Large working range: 3,124 mm
- Particularly suitable for large and bulky workpieces
- Hollow arm for optimal media supply

Controlled by
YRC1000

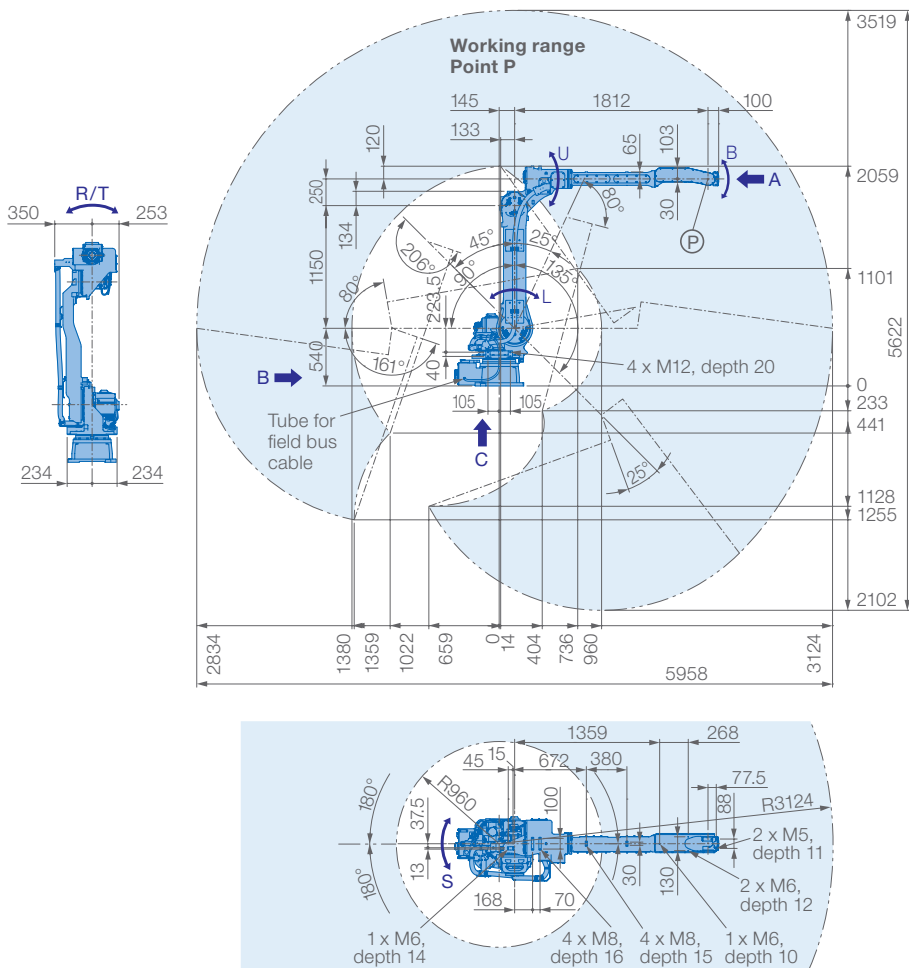

ViewA

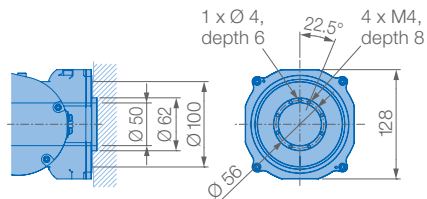

ViewB

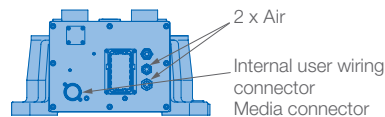

ViewC

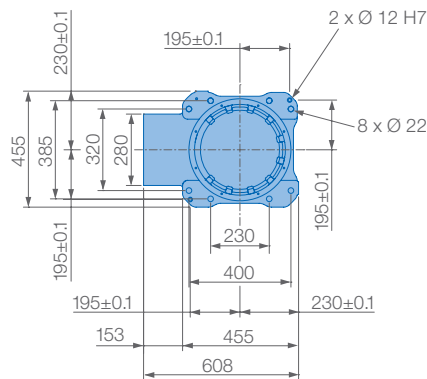

Allowable wrist load

Prevent interaction of the robot with:

- Corrosive gases, liquids or explosive gases
- Exposure to water, oil or dust
- Excessive electrical noise (plasma)

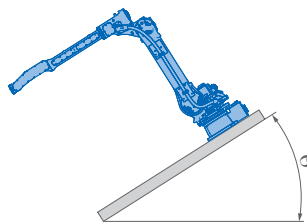
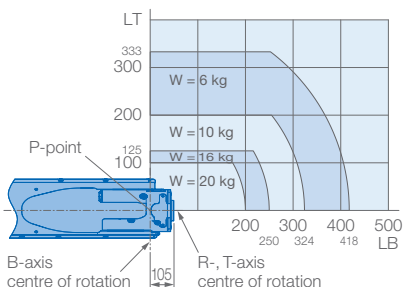

Mounting options: Floor, ceiling, wall, tilt*
Protection class version YR-1-06VXHL20-C00
Standard: IP65/67
Protection class version YR-1-06VXHL20-D00:
IP54/67

Robot installation angle θ [deg.]	S-axis operating range [deg.]
0 ≤ θ ≤ 30	±180 degrees or less (no limit)
30 < θ ≤ 35	±60 degrees or less
35 < θ ≤ 45	±45 degrees or less
45 < θ	±30 degrees or less

* tilt with condition of angle – see table

Specifications GP20HL						
Axes	Maximum motion range [°]	Maximum speed [°/s]	Allowable moment [Nm]	Allowable moment of inertia [kg · m²]	Controlled axes	6
S	±180	180	–	–	Max. payload [kg]	20
L	+135/–90	180	–	–	Repeatability [mm]	±0.07
U	+206/–80	180	–	–	Max. working range R [mm]	3124
R	±200	400	39.2	1.05	Temperature [°C]	0 to +45
B	±150	430	39.2	1.05	Humidity [%]	20 – 80
T	±455	630	19.6	0.75	Weight [kg]	560
					Power supply, average [kVA]	4.0

MOTOMAN GP25, GP25-12

Handling & General Applications
with the GP Series



The MOTOMAN GP25 is a fast and precise 6-axis industrial robot with a payload capacity of up to 25 kg. With a reach of 1730 mm and a high repeatability of ± 0.02 mm, it is ideally suited to assembly tasks, but also universal handling tasks, CNC machine tool tending or packaging. With its payload capacity of 12 kg, the MOTOMAN GP25-12 offers an even larger working range of 2010 mm with a repeatability of ± 0.03 mm. The streamlined modern industrial design minimizes the space requirements at the installation site.

Cable entry from the side at the pedestal enables space-saving and uncluttered integration into the environment, irrespective of the intended installation position. The prepared routing of the supply lines in the arm enables optimal integration of the grippers or sensor systems, often dispensing with the need for an external media package. This reduces also interference contours.

A world of possibilities is open to the MOTOMAN GP25/GP25-12 robots with the numerous functions of the MOTOMAN YRC1000 controller. In conjunction with the conventional teach pendant, these robots are reliable mechanical engineering partners. With the innovative operator control concept of the SmartPendant, it provides an excellent point of entry into industrial automation.

As standard, the MOTOMAN GP25 and GP25-12 are designed with the high protection classification IP67 (wrist). Other variants of the MOTOMAN GP25 (e.g. with food-compatible grease in the food industry, special anti-corrosion coating for applications in aggressive ambient conditions, or as a cleanroom version) are optionally available.

KEY BENEFITS

- Flexible, fast and powerful
- Large working range: 1730 and 2010 mm
- Reduced interference contours due to optimized design
- Simple commissioning and maintenance

Controlled by
YRC1000

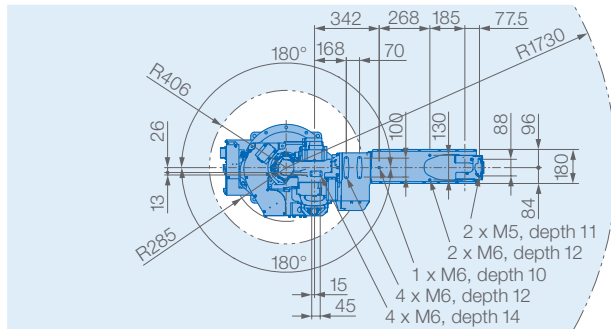
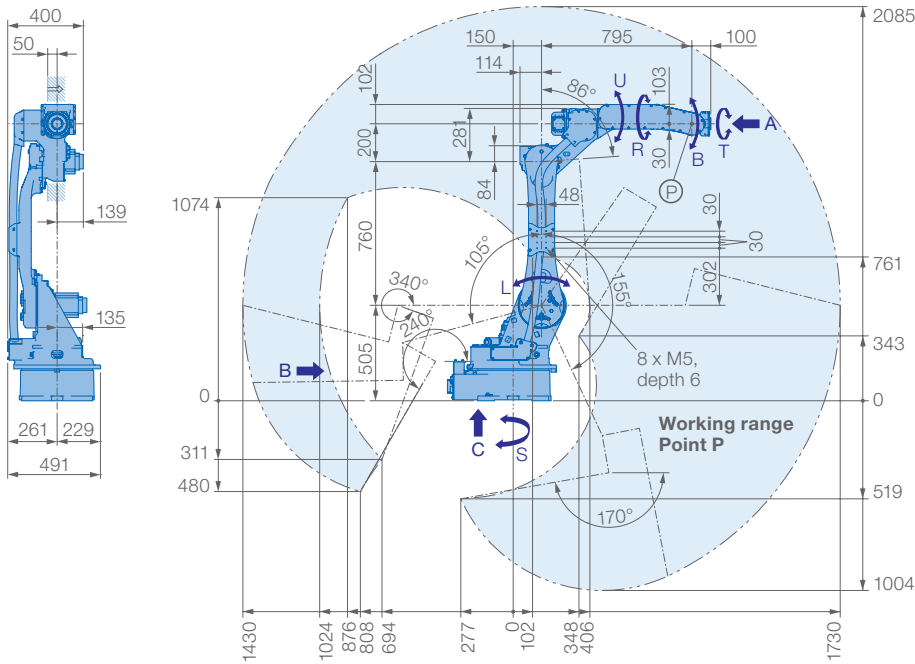

View A

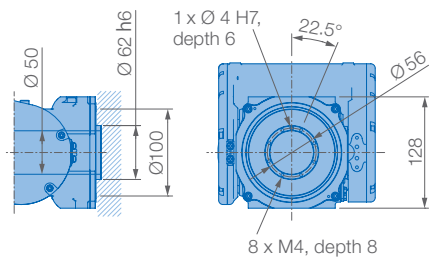

View B

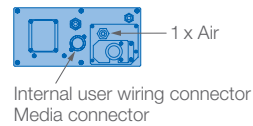

View C

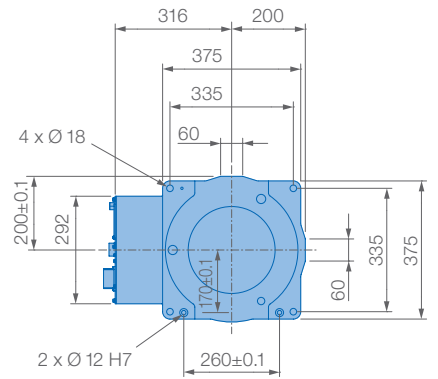

Allowable wrist load

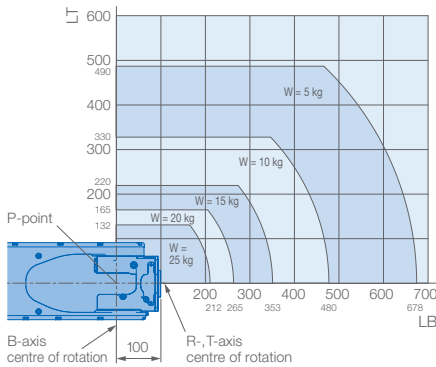

Prevent interaction of the robot with:

- Corrosive gases, liquids or explosive gases
- Exposure to water, oil or dust
- Excessive electrical noise (plasma)

Mounting options: Floor, ceiling, wall, tilt*

Protection class version YR-1-25VXH25-A00
Standard: Main axes (S, L, U) IP54, wrist IP67

Protection class version YR-1-25VXH25-C00:
Main axes (S, L, U) IP65, wrist IP67

Protection class version YR-1-06VXH25-C02 (ACC):
Main axes (S, L, U) IP65, wrist IP67

* tilt with condition of angle – see table below

Robot installation angle θ [deg.]	S-axis operating range [deg.]
$0 \leq \theta \leq 30$	± 180 max. no limit
$30 < \theta \leq 35$	± 60 max.
$35 < \theta$	± 30 max.

Specifications GP25

Axes	Maximum motion range [°]	Maximum speed [°/s]	Allowable moment [Nm]	Allowable moment of inertia [kg · m ²]	Controlled axes	6
S	± 180	210	–	–	Max. payload [kg]	25
L	$+155/-105$	210	–	–	Repeatability [mm]	$\pm 0.02^*$
U	$+160/-86$	265	–	–	Max. working range R [mm]	1730
R	± 200	420	52	2.3	Temperature [°C]	0 to +45
B	± 150	420	52	2.3	Humidity [%]	20 – 80
T	± 455	885	32	1.2	Weight [kg]	250
					Power supply, average [kVA]	2,0**

* Conforms to ISO 9283 ** Varies in accordance with applications and motion patterns **Note:** SI units are used for specifications.

All dimensions in mm

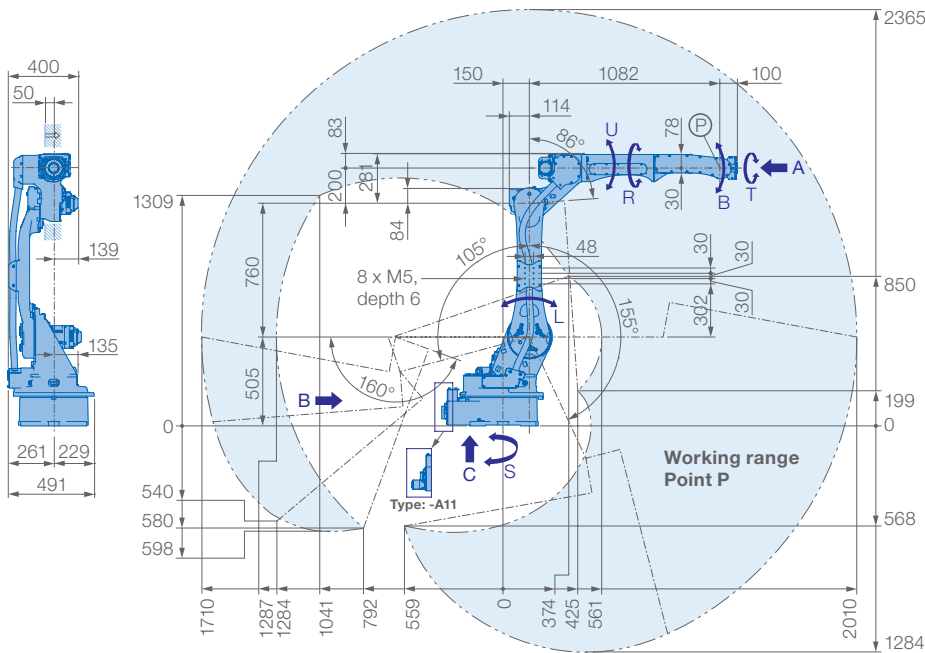

View A

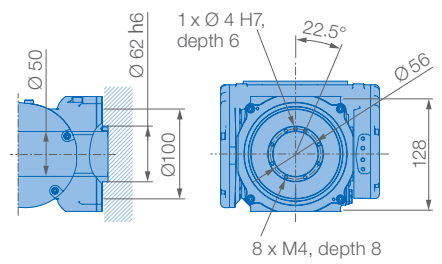

View B

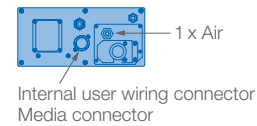

View C

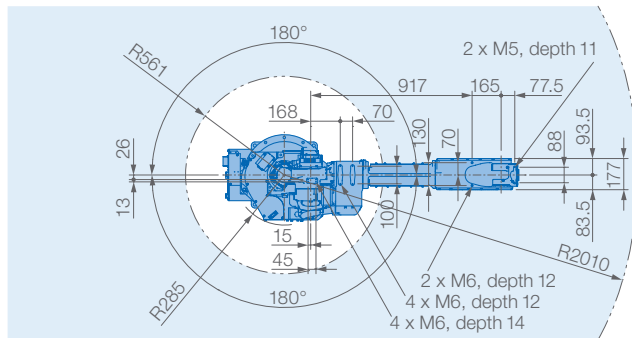
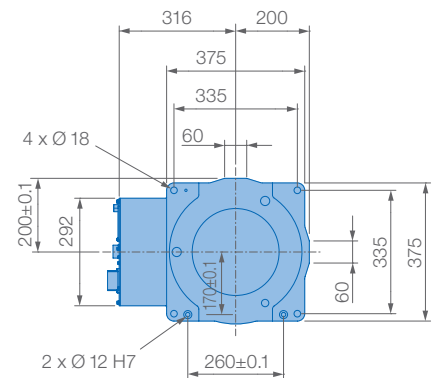

Prevent interaction of the robot with:

- Corrosive gases, liquids or explosive gases
- Exposure to water, oil or dust
- Excessive electrical noise (plasma)

Mounting options: Floor, ceiling, wall, tilt*

Protection class: Main axes (S, L, U) IP54 (option 65), wrist IP67

* tilt with condition of angle – see table below



Allowable wrist load

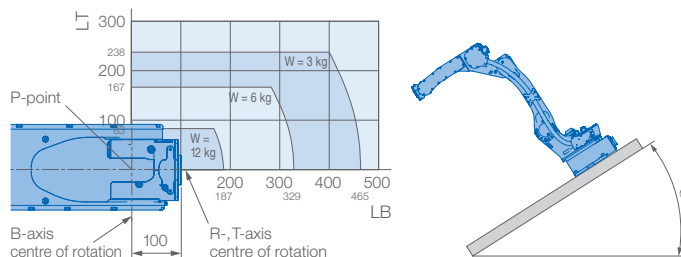

Robot installation angle Θ [deg.]	S-axis operating range [deg.]
$0 \leq \Theta \leq 30$	± 180 max. no limit
$30 < \Theta \leq 35$	± 60 max.
$35 < \Theta$	± 30 max.

Specifications GP25-12

Axes	Maximum motion range [°]	Maximum speed [°/s]	Allowable moment [Nm]	Allowable moment of inertia [kg · m ²]	Controlled axes	6
S	± 180	210	–	–	Max. payload (on U-axis) [kg]	12 (9)
L	$+155/-105$	210	–	–	Repeatability [mm]	$\pm 0.03^*$
U	$+160/-86$	220	–	–	Max. working range R [mm]	2010
R	± 200	435	22	0.65	Temperature [°C]	0 to +45
B	± 150	435	22	0.65	Humidity [%]	20 – 80
T	± 455	700	9.8	0.17	Weight [kg]	260
					Power supply, average [kVA]	2.0**

* Conforms to ISO 9283 ** Varies in accordance with applications and motion patterns Note: SI units are used for specifications.

All dimensions in mm



YASKAWA

HW1617
© 17

MOTOMAN GP35L

Handling & General Applications
with the GP Series



The MOTOMAN GP35L is a dynamic, high-speed robot featuring an extended reach for large parts. It offers superior performance in laser welding, coating, dispensing, gluing, material cutting and material handling applications.

KEY BENEFITS

- High repeatability: ± 0.07 mm
- Ideal for a variety of applications, multi-purpose robot
- Wide motion range
- Small interference radius reduces floorspace requirements
- Specifically designed for processing large parts
- Protection class IP54/67 as standard

Controlled by
YRC1000

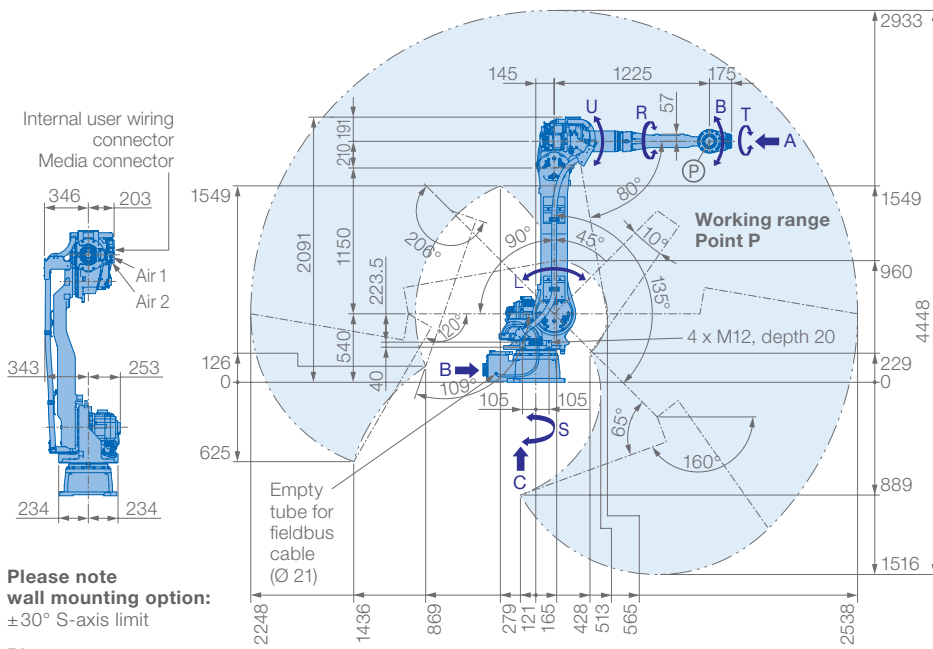

Please note wall mounting option:
±30° S-axis limit

Please note ceiling mounting option:
Please notice working range of B-axis

Please note tilted robot:
0°–90° limitation of S-axis, details on request

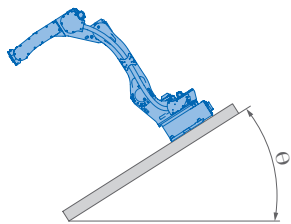

Robot installation angle θ [deg.]	S-axis operating range [deg.]
$0 \leq \theta \leq 30$	±180 (Standard)
$30 < \theta \leq 35$	±60
$35 < \theta \leq 45$	±45
$45 < \theta$	±45

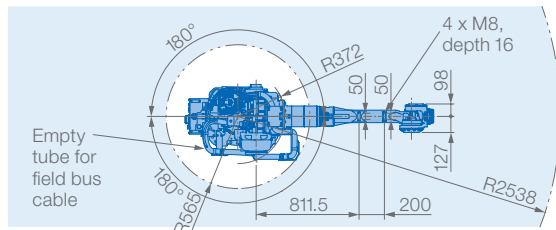

Allowable wrist load

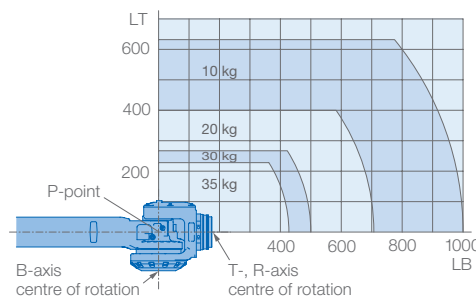

View A

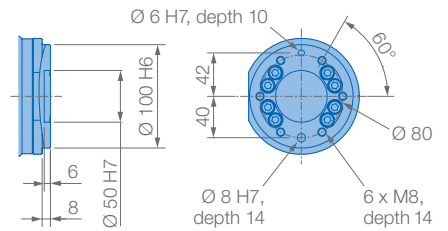

View B

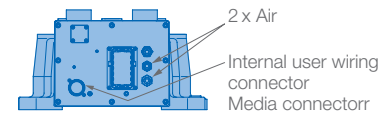

View C

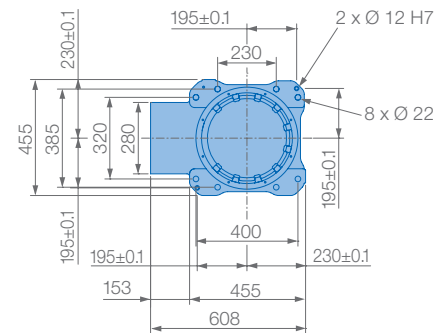

Mounting options: Floor, ceiling, wall, tilt*

Protection class version YR-1-06VXL35-A00
Standard: Main axes (S, L, U) IP54, wrist IP67

Protection class version YR-1-06VXL35-C00:
Main axes (S, L, U) IP65, wrist IP67

* tilt with condition of angle – see table below

Wrist + U-arm in front	Up to 35 kg for attaching load mass including wrist load
U-arm behind	Up to 10 kg, 49 N · m (5 kgf · m) max. for increased moment amount of upper arm (floor-, ceiling-mounted type only)
S-axis below	Up to 30 kg (floor-, ceiling-mounted type only)

Specifications GP35L

Axes	Maximum motion range [°]	Maximum speed [°/sec.]	Allowable moment [Nm]	Allowable moment of inertia [kg · m ²]	Controlled axes	6
S	±180	180	–	–	Max. payload [kg]	35
L	+135/–90	140	–	–	Repeatability [mm]	±0.07
U	+206/–80	178	–	–	Max. working range R [mm]	2538
R	±360	250	147	10	Temperature [°C]	0 to +45
B	±125	250	147	10	Humidity [%]	20 – 80
T	±360	360	78	4	Weight [kg]	600
					Power supply, average [KVA]	4.0

MOTOMAN GP35H

Handling & General Applications
with the GP Series



The MOTOMAN GP35H is a high-speed hollow wrist robot featuring an extended reach for large parts. The electrical and additional cables run through the inside of the wrist, which improves the mobility of the robot and at the same time minimises the risk of damage; there are no interfering contours due to external cable packages.

This 35 kg payload robot is suitable for a precise medium payload applications like pick & place, machine loading, material handling, assembly, dosing and deburring as well as grinding. As no interference factors need to be taken into account, this robot offers superior performance in vision applications, offline and on-site teaching operations and is advantageous in offline programming.

The internal cable routing allows maximum acceleration and thus fast and reliable movements. As a result of its high moment of inertia, the GP35H handles large grippers and parts within large working ranges with its reach of 2070 mm.

KEY BENEFITS

- Internal cable routing eliminates interference contours, cable snagging and enables maximum acceleration
- High speed and high precision
- Dust and liquid-tight wrist (protection class IP67)
- Large horizontal reach

Controlled by
YRC1000

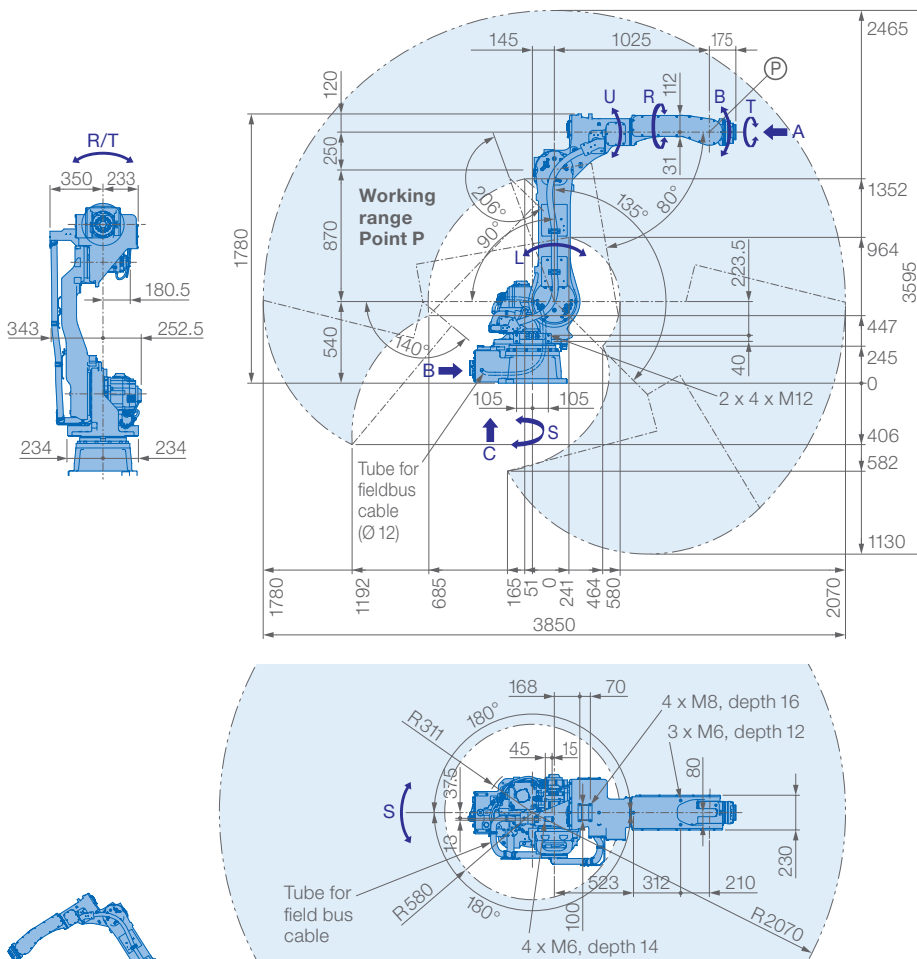

View A

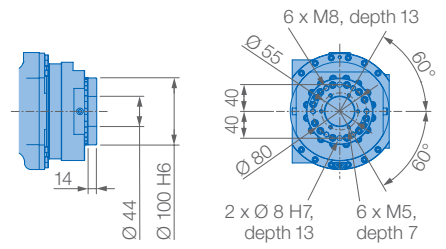

View B

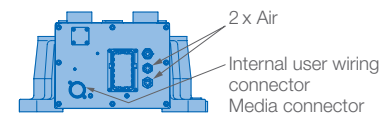

View C

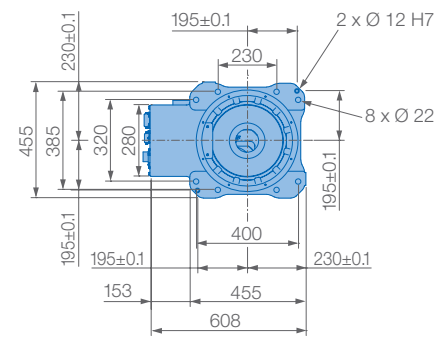

Mounting options: Floor, ceiling, wall, tilt*

Protection class version YR-1-06VXH35-A00
Standard: Main axes (S, L, U) IP54, wrist IP67

* tilt with condition of angle – see table below

Wrist + U-arm in front	Up to 35 kg for attaching load mass including wrist load
U-arm behind	Up to 10 kg. 49 N · m max. for increased moment amount of upper arm (floor-, ceiling-mounted type only)
S-axis below	Up to 30 kg (floor-, ceiling-mounted type only)

Allowable wrist load

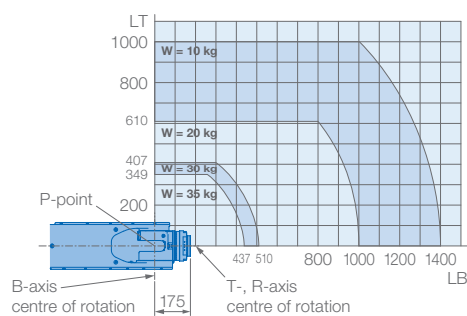

Robot installation angle θ [deg.]	S-axis operating range [deg.]
$0 \leq \theta \leq 30$	± 180 (Standard)
$30 < \theta \leq 35$	± 60
$35 < \theta \leq 45$	± 45
$45 < \theta$	± 30

Specifications GP35H					
Axes	Maximum motion range [°]	Maximum speed [°/sec.]	Allowable moment [Nm]	Allowable moment of inertia [kg · m ²]	Controlled axes
S	±180	180	–	–	6
L	+135/–90	180	–	–	Max. payload [kg]
U	+206/–80	200	–	–	Repeatability [mm]
R	±200	350	150	20	Max. working range R [mm]
B	±125	350	150	20	Temperature [°C]
T	±360	400	120	10	Humidity [%]
					Weight [kg]
					Power supply, average [KVA]

MOTOMAN GP50

Handling & General Applications
with the GP Series



The MOTOMAN GP50 is a versatile, high speed 6-axis robot offering superior performance in material handling, machine tending, processing and dispensing applications.

Due to its compact design, the GP50 can be placed close to machines for loading and unloading of parts.

KEY BENEFITS

- Fast, flexible and reliable
- Ideal for a variety of applications, multi-purpose robot
- Robot with sleek design that requires minimal installation space
- 50 kg payload

Controlled by
YRC1000

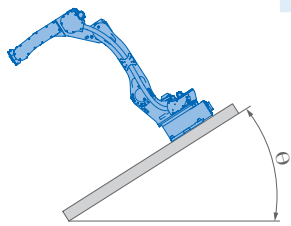
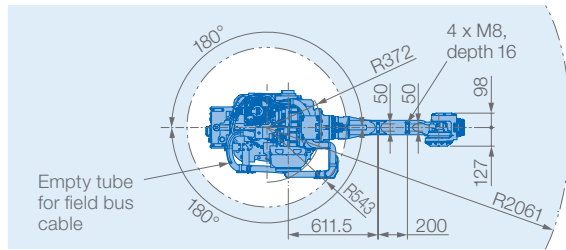
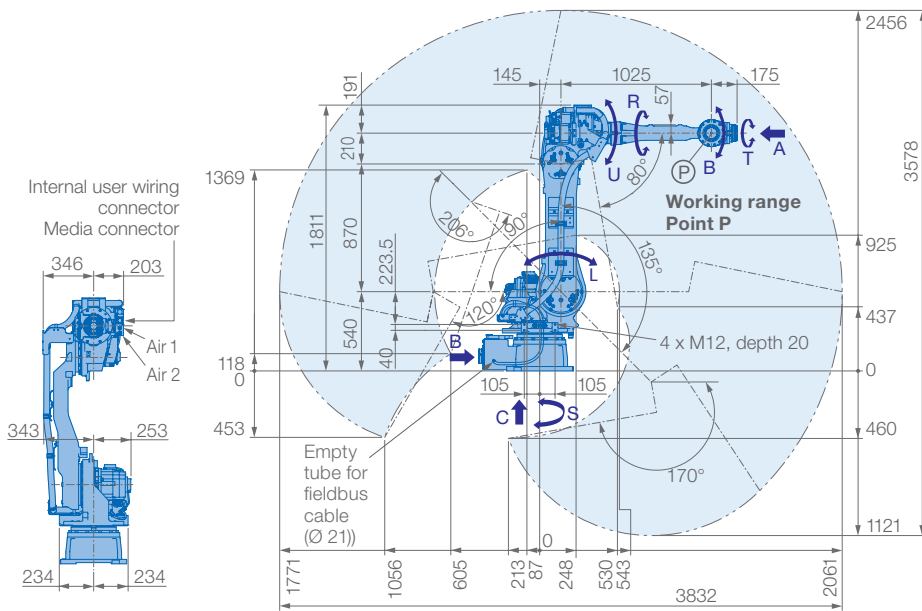

Robot installation angle θ [deg.]	S-axis operating range [deg.]
$0 \leq \theta \leq 30$	± 180 (Standard)
$30 < \theta \leq 35$	± 60
$35 < \theta \leq 45$	± 45
$45 < \theta$	± 30

Allowable wrist load

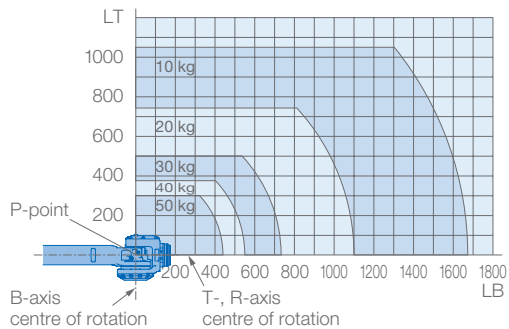

View A

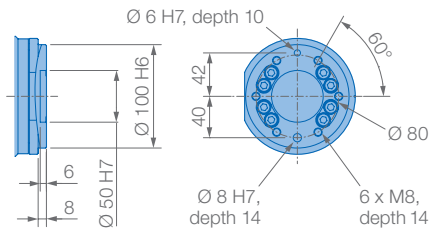

View B

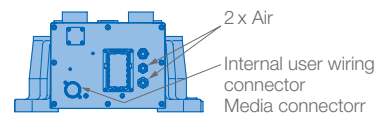

View C

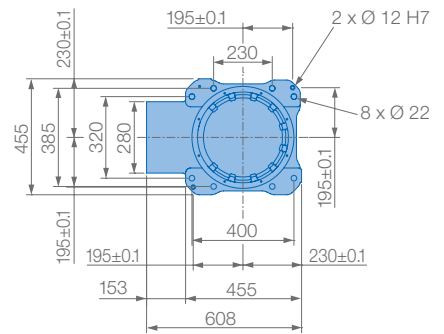

Mounting options: Floor, ceiling, wall, tilt*

Protection class version YR-1-06VX50-A00
Standard: Main axes (S, L, U) IP54, wrist IP67

Protection class version YR-1-06VX50-C00:
Main axes (S, L, U) IP65, wrist IP67

Please notice wall mounting option:
 $\pm 30^\circ$ S-axis limit

Please notice ceiling mounting option:
Please notice working range of B-axis

Please notice tilted robot:
 $0^\circ - 90^\circ$ limitation of S-axis, details on request

* tilt with condition of angle – see table left side

Specifications GP50					
Axes	Maximum motion range [°]	Maximum speed [°/sec.]	Allowable moment [Nm]	Allowable moment of inertia [kg · m ²]	Controlled axes
S	± 180	180	–	–	6
L	$+135/-90$	178	–	–	Max. payload [kg]
U	$+206/-80$	178	–	–	Repeatability [mm]
R	± 360	250	216	28	Max. working range R [mm]
B	± 125	250	216	28	Temperature [°C]
T	± 360	360	147	11	Humidity [%]
					Weight [kg]
					Power supply, average [KVA]

MOTOMAN GP70L

Picking & Handling
with the GP Series



The fast and dynamic 6-axis MOTOMAN GP70L robot offers top performance for order picking as well as item, box and carton handling in the logistics industry. The most powerful robot in its class offers a huge increase in terms of efficiency and productivity for sorting and packing in intralogistics applications.

With a payload of 70 kg and an enormous reach of 2,732 mm, its slim design allows it to operate in the tightest of spaces, resulting in a high robot density. The narrow cable routing further reduces the width of the robot. The modern picking and handling robot can flexibly supplement or replace manual stations, and in combination with additional peripherals (e.g., 3D vision technology), it increase economic efficiency.

The MOTOMAN GP70L operates with powerful servo motors of the Yaskawa Sigma-7 generation, which ensure the highest accelerations with short movements for even shorter cycle times. The reduced cycle times further increase productivity. The ideal combination is with the optional Functional Safety Control (FSU) for safeguarding compact work areas, which is already integrated in the compact MOTOMAN YRC1000 high-performance controller.

KEY BENEFITS

- Unique in its class → especially for the logistics industry
- New Sigma-7 servo motors → high acceleration, speeds, smaller size and power requirements
- High payload: 70 kg
- Large working range: 2,732 mm
- Robust and flexible
- Slim, compact and low profile design
- Advanced safety function (FSU) in the control system (YRC1000)
- PLC integration via MotoLogix software interface
- Wrist resistant to intrusion of dust and liquids (IP54/IP67)

Controlled by
YRC1000

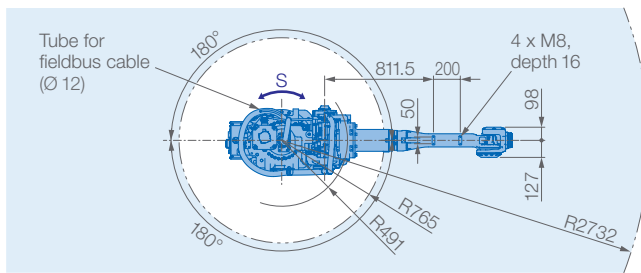
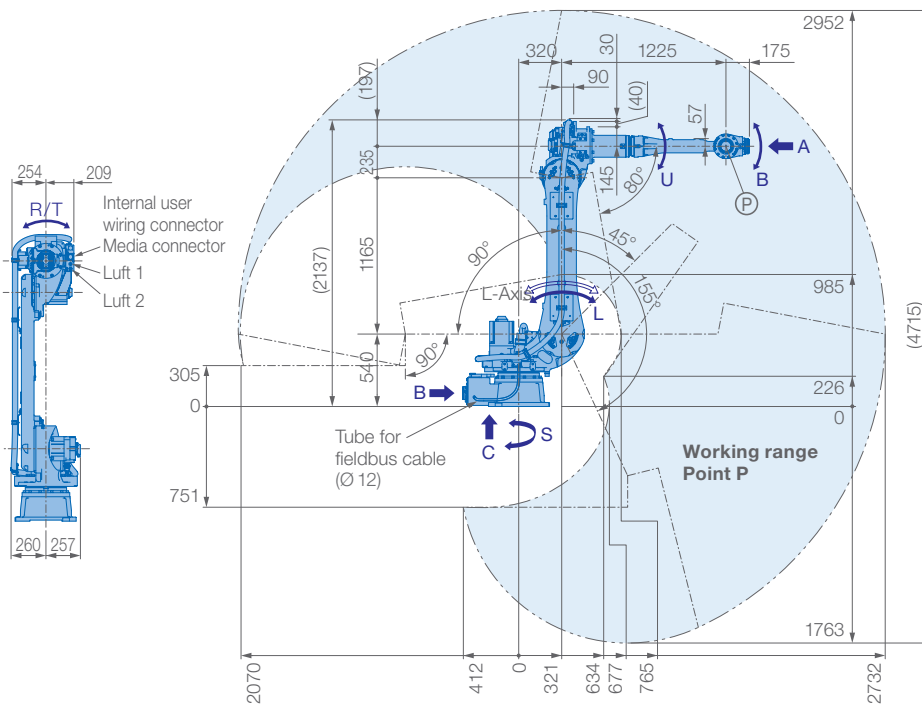

Allowable wrist load

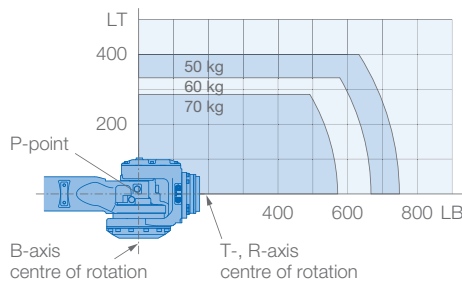

View A

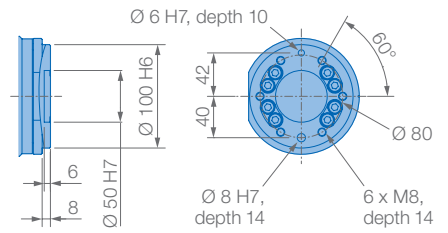

View B

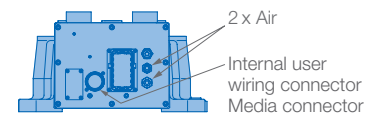

View C

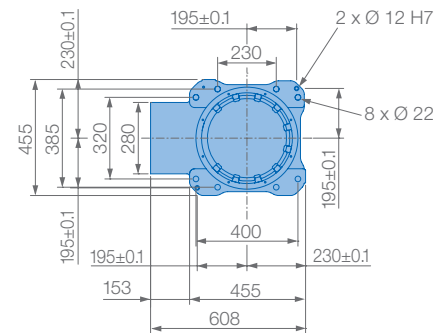

Mounting option: Floor

IP Protection: Main axes (S, L, U) IP54, wrist IP67

Specifications GP70L

Axes	Maximum motion range [°]	Maximum speed [°/sec.]	Allowable moment [Nm]	Allowable moment of inertia [kg · m ²]	Controlled axes	6
S	±180	180	-	-	Max. payload [kg]	70
L	+155/-90	123	-	-	Repeatability [mm]	±0.05
U	+90/-80	160	-	-	Max. working range R [mm]	2732
R	±360	230	392	28	Temperature [°C]	0 to +45
B	±125	230	392	28	Humidity [%]	20 - 80
T	±360	350	196	11	Weight [kg]	650
					Power supply, average [KVA]	5.0

MOTOMAN GP88

Handling & General Applications
with the GP Series



The MOTOMAN GP88 is a versatile high speed 6-axis robot, providing a high payload of up to 88 kg. It offers superior performance in material handling, machine tending, processing and dispensing applications.

Despite its slim body, the MOTOMAN GP88 features a wide work envelope with a small interference radius. Thereby it can be placed close to machines for loading and unloading of parts, which reduces the required floor space to a minimum.

KEY BENEFITS

- Flexible and powerful (payload of 88 kg)
- High axis speeds
- Improved wrist ratings provide higher handling capacity
- Small interference radius reduces floor space requirements

Controlled by
YRC1000

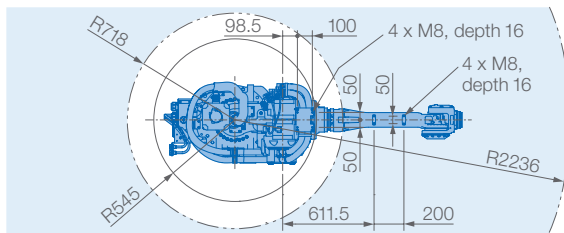
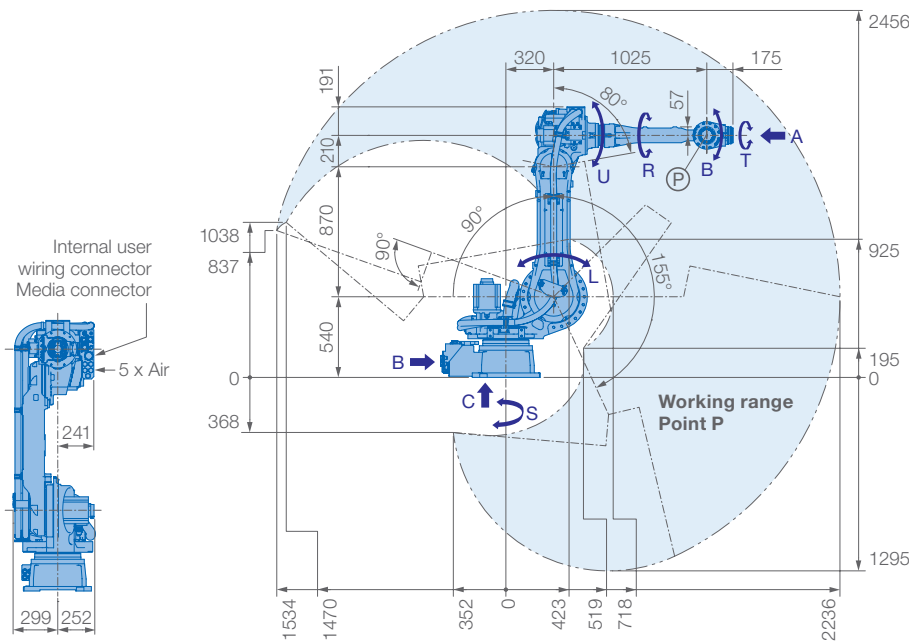

View A

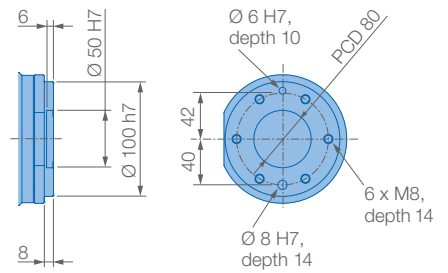

View B

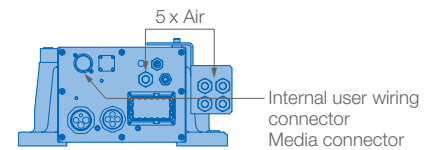

View C

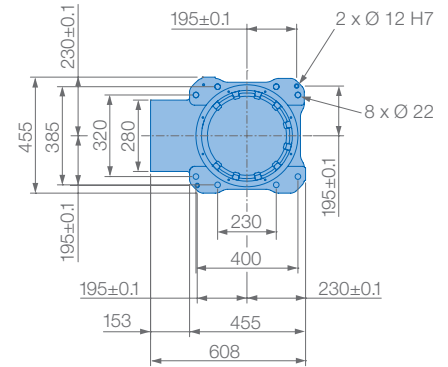

Mounting options: Floor, ceiling, wall, tilt*
 Protection class version YR-1-06VX88-A00
 Standard: Main axes (S, L, U) IP54, wrist IP67
 Protection class version YR-1-06VX88-C00:
 Main axes (S, L, U) IP65, wrist IP67

Please notice: Just valid for body/wrist, connector base not protected
 * tilt with condition of angle – see table left side

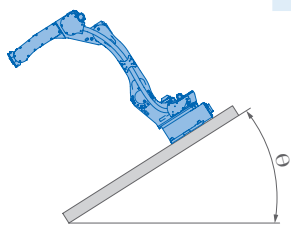

Robot installation angle θ [deg.]	S-axis operating range [deg.]
$0 \leq \theta \leq 30$	± 180 (Standard)
$30 < \theta \leq 35$	± 60
$35 < \theta \leq 45$	± 45
$45 < \theta$	± 30

Allowable wrist load

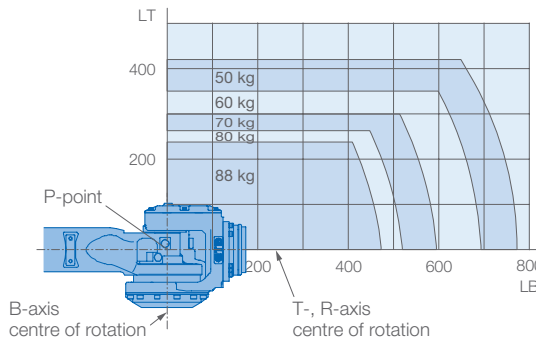

Specifications GP88					
Axes	Maximum motion range [°]	Maximum speed [°/sec.]	Allowable moment [Nm]	Allowable moment of inertia [kg · m²]	Controlled axes
S	± 180	170	–	–	6
L	+155/–90	140	–	–	Max. payload [kg]
U	+90/–80	160	–	–	88
R	± 360	230	408	30	Repeatability [mm]
B	± 125	230	408	30	± 0.03
T	± 360	350	206	11	Max. working range R [mm]
					2236
					Temperature [°C]
					0 to +45
					Humidity [%]
					20 – 80
					Weight [kg]
					630
					Power supply, average [KVA]
					4.0

MOTOMAN GP110

Handling & General Applications
with the GP Series



The 6-axis MOTOMAN GP110 is a versatile, high speed robot offering superior performance for a variety of applications, for example material handling, machine and press tending.

Despite of providing a wide motion range and high payload of 110 kg, the MOTOMAN GP110 has a streamlined design, which allows extremely close positioning of several robots. Also the slim cable inlet reduces the robots width, therefore valuable floor space can be saved.

The MOTOMAN GP110 is available with the PLd Category 3 Functional Safety Unit (FSU).

KEY BENEFITS

- Fast and flexible
- Wide motion range: 2236 mm
- High payload: 110 kg
- Compact design
- Slim cable inlet
- Enhanced safety functions

Controlled by
YRC1000

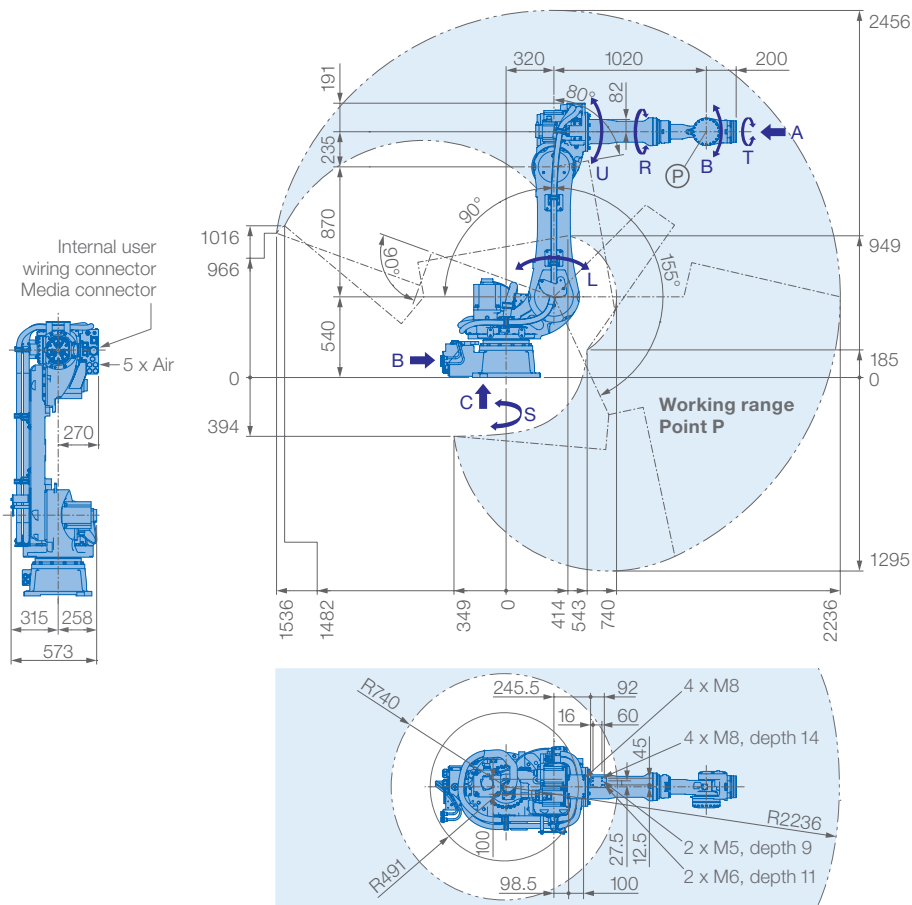

View A

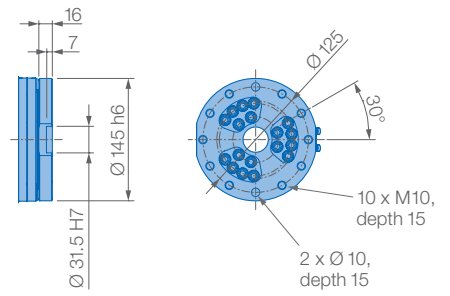

View B

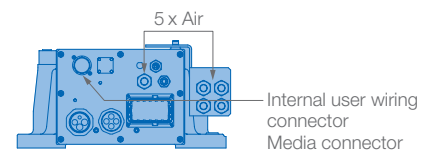

View C

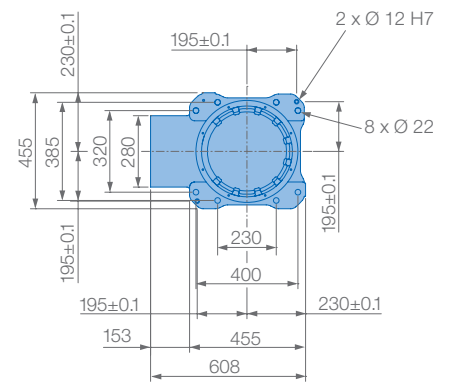

Allowable wrist load

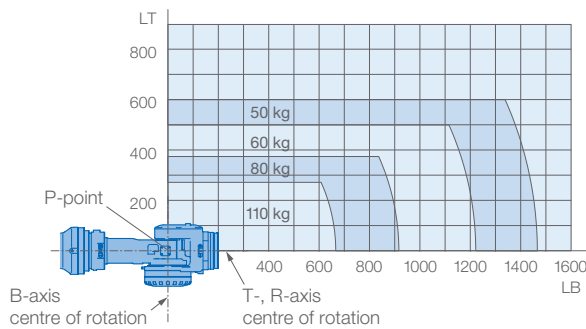

Mounting option: Floor

Protection class version YR-1-06VX110-A00
Standard: Main axes (S, L, U) IP54, wrist IP67

Protection class version YR-1-06VX110-C00:
Main axes (S, L, U) IP65, wrist IP67

Specifications GP110						
Axes	Maximum motion range [°]	Maximum speed [°/sec.]	Allowable moment [Nm]	Allowable moment of inertia [kg · m²]	Controlled axes	6
S	±180	140	-	-	Max. payload [kg]	110
L	+155/-90	110	-	-	Repeatability [mm]	±0.03
U	+90/-80	130	-	-	Max. working range R [mm]	2236
R	±360	175	721	60	Temperature [°C]	0 to +45
B	±125	175	721	60	Humidity [%]	20 - 80
T	±360	255	294	33.7	Weight [kg]	660
					Power supply, average [KVA]	5.0

MOTOMAN GP180-120

Handling & General Applications
with the GP Series



This powerful six-axis handling robot features high speed motion which reduce cycle times.

High payload and increased moment and inertia ratings allows the MOTOMAN GP180-120 the handling of large and heavy payloads. Its streamlined upper arm design features a slim wrist profile and reduces robot width. This enables easier reach into confined spaces, improving application flexibility. Therefore the MOTOMAN GP180-120 can be mounted closer to machines and fixtures, making best use of valuable floor space.

Its cables and airlines are routed through the robot base to upper arm to increase cable life, enhance safety and reduce teaching time.

The cable installation tube in the base of the robot facilitates fieldbus routing to the robot upper arm and/or gripper. It is also pre-wired for servo gripper which allows a wider range of product handling.

The MOTOMAN GP180-120 has an IP67-rated wrist and an IP54 body standard.

KEY BENEFITS

- Small footprint and minimal interferences
- High inertia rating enables handling of huge work pieces
- Reduced cycle times by optimal design and high axes speed
- Versatile use in various applications
- High density spacing and reaching into confined spaces

Controlled by
YRC1000

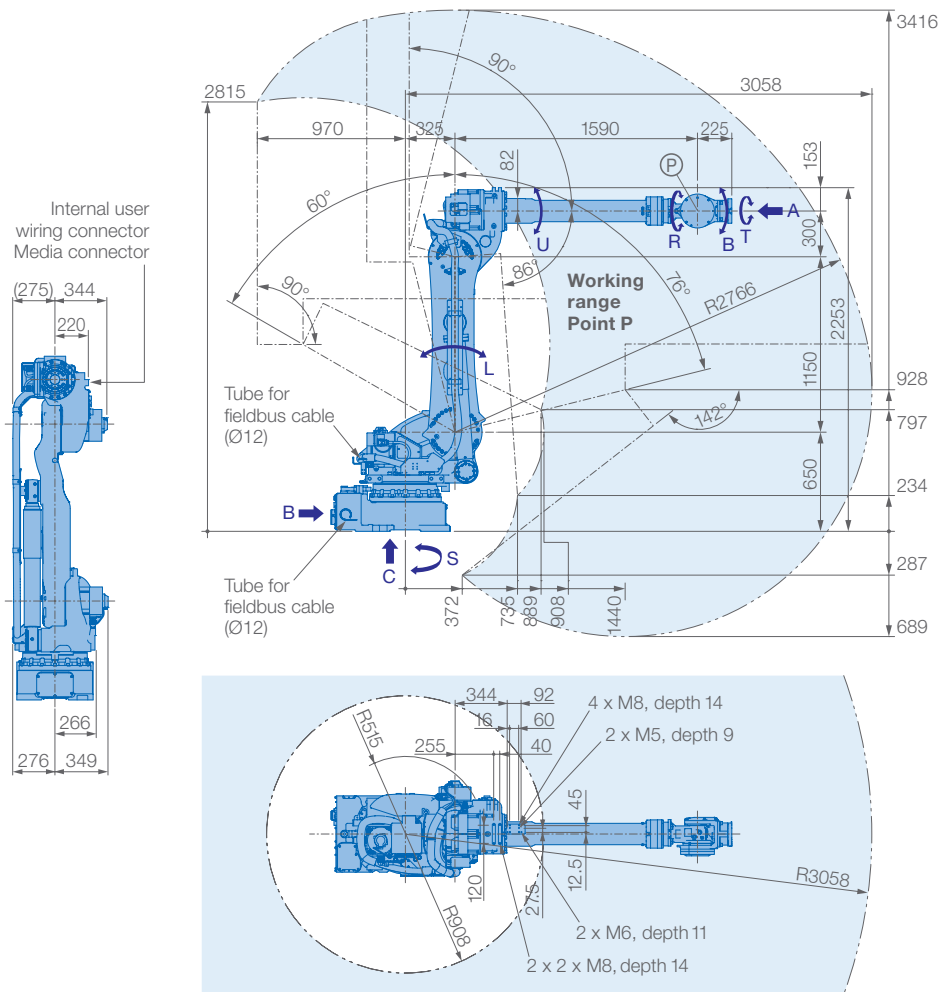

View A

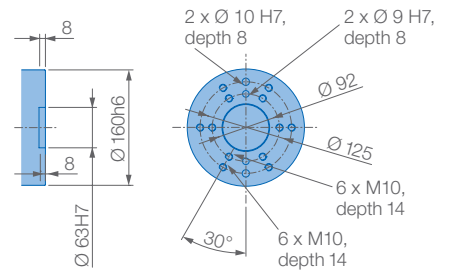

View B

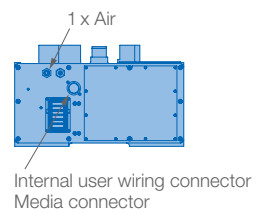

View C

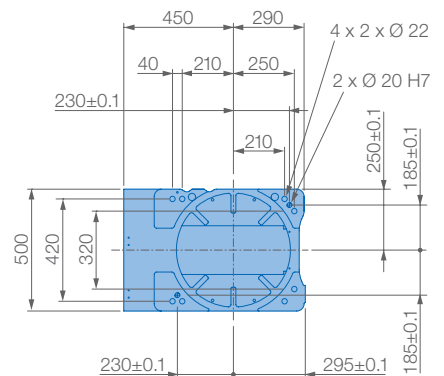

Mounting option: Floor
Protection class: IP54/IP67

Allowable wrist load

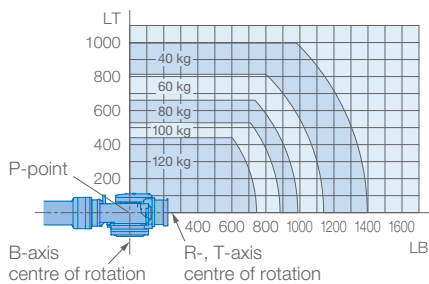

Specifications GP180-120					
Axes	Maximum motion range [°]	Maximum speed [°/s]	Allowable moment [Nm]	Allowable moment of inertia [kg · m ²]	Controlled axes
S	±180	125	-	-	6
L	+76/-60	115	-	-	Max. payload [kg]
U	+90/-86	125	-	-	Repeatability [mm]
R	±360	182	883	79	Max. working range R [mm]
B	±130	175	883	79	Temperature [°C]
T	±360	265	520	40	Humidity [%]
					Weight [kg]
					Power supply, average [kVA]

MOTOMAN GP180

Handling & General Applications
with the GP Series



The 6-axis MOTOMAN GP180 is a versatile, high speed robot offering superior performance for a variety of applications, like material handling, machine and press tending.

Despite of providing a high payload of 180 kg and the wide motion range of 2702 mm, the MOTOMAN GP180 was designed with a width of 625 mm, therefore valuable floor space can be saved.

With the higher axis operation speed and speed reducer rigidity, a special vibration control system was developed. By reducing cycle times, this system realises high increases in productivity.

KEY BENEFITS

- Fast, flexible and powerful
- High payload: 180 kg
- Wide motion range: 2702 mm
- Maximum performance using minimal floor space

Controlled by
YRC1000

MOTOMAN GP215

Handling & General Applications
with the GP Series



The 6-axis MOTOMAN GP215 is a versatile, high speed robot offering superior performance for a variety of applications, like material handling, machine and press tending.

Despite of providing a high payload of 215 kg and the wide motion range of 2912 mm, the MOTOMAN GP215 was designed with a width of 816 mm, therefore valuable floor space can be saved.

The vibration control system uses higher axis operation speed and speed reducer rigidity to allow fast acceleration of short movements. By reducing cycle times, this system realises high increases in productivity.

KEY BENEFITS

- Fast, flexible and powerful
- High payload: 215 kg
- Wide motion range: 2912 mm
- Maximum performance using minimal floor space

Controlled by
YRC1000

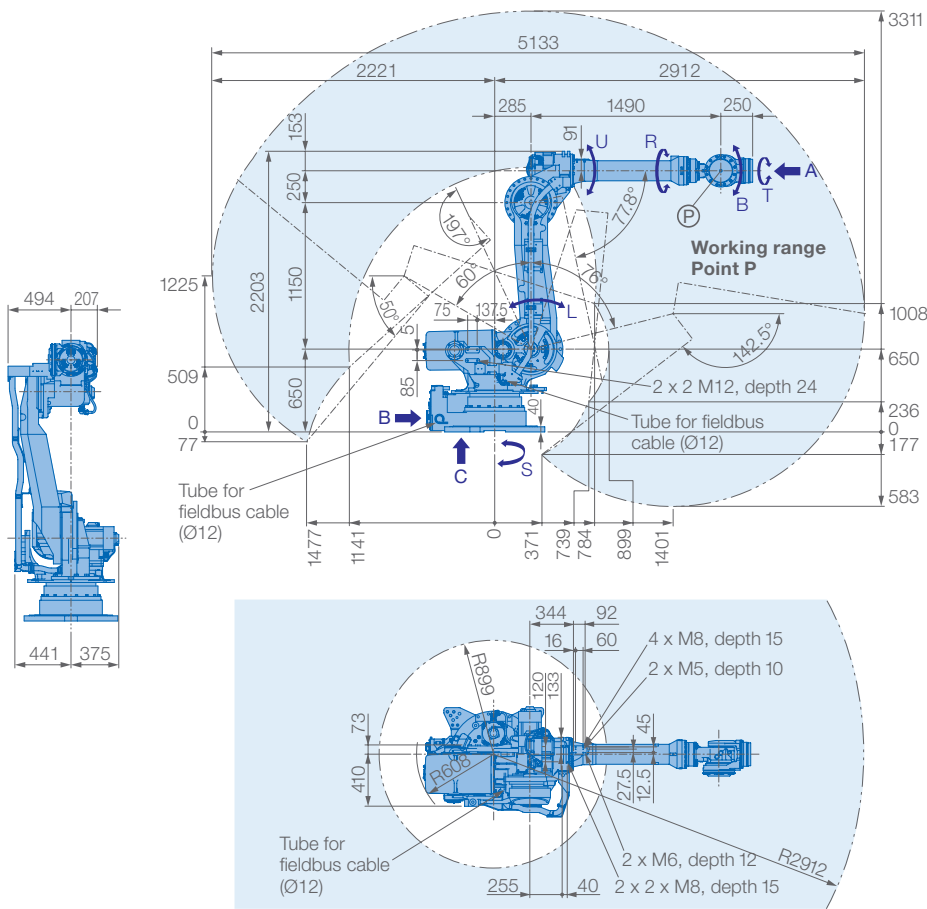

View A

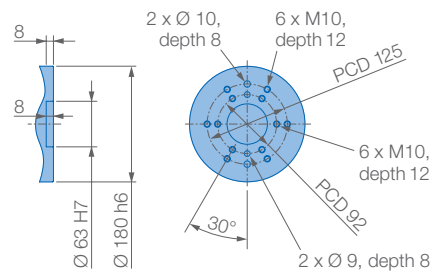

View B

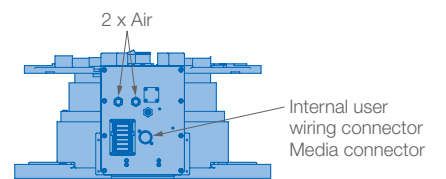

View C

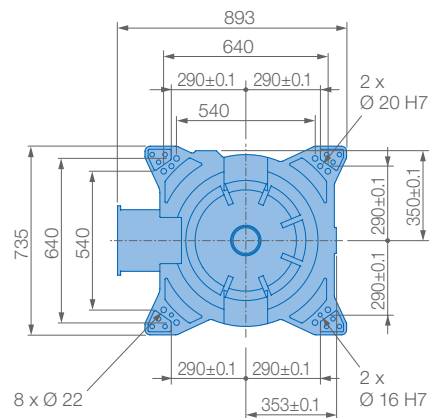

Mounting option: Floor
Protection class: IP54/IP67

Allowable wrist load

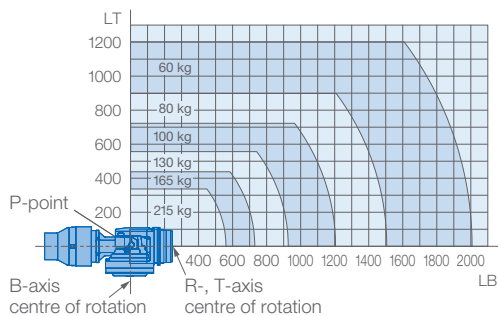

Specifications GP215						
Axes	Maximum motion range [°]	Maximum speed [°/s]	Allowable moment [Nm]	Allowable moment of inertia [kg · m ²]	Controlled axes	6
S	±180	100	-	-	Max. payload [kg]	215
L	+76/-60	90	-	-	Repeatability [mm]	±0.05
U	+197/-77.8	97	-	-	Max. working range R [mm]	2912
R	±360	120	1176	317	Temperature [°C]	0 to +45
B	±125	120	1176	317	Humidity [%]	20 - 80
T	±360	190	710	200	Weight [kg]	1340
					Power supply, average [kVA]	5.0

MOTOMAN GP215-200T

Handling & General Applications
with the GP Series



The flexible, 6-axis handling robot MOTOMAN GP215-200T is specifically designed for ceiling-mounted applications and provides a high payload of 200 kg with a large reach of 2,676 mm.

It offers top performance especially where a robot is mounted elevated on a steel structure to create space on the floor for conveyors, fixtures or processing machines. With its slim arm, it can be used effortlessly in the tightest work spaces. Typical applications for the MOTOMAN GP215-200T include loading operations with longer transport distances and spot welding applications.

High performance Sigma-7 drive technology enables the robot to perform fast, dynamic movements and accelerations with high repeatability.

Combined with the powerful MOTOMAN YRC1000 robot controller and an extensive portfolio of gantries and consoles, the MOTOMAN GP215-200T is a versatile and reliable industrial robot.

KEY BENEFITS

- High payload: 200 kg
- Large working range: 2,676 m
- Space-saving ceiling mounting
- Slim arm for use in confined work spaces
- Fast movements due to high axis speeds and acceleration

Controlled by
YRC1000

MOTOMAN GP225

Handling & General Applications
with the GP Series



The 6-axis MOTOMAN MH225 is a versatile, high speed robot offering superior performance for a variety of applications, like material handling, machine and press tending.

Despite of providing a high payload of 225 kg and the wide motion range of 2702 mm, the MOTOMAN GP225 was designed with a width of 625 mm, therefore valuable floor space can be saved.

With the higher axis operation speed and speed reducer rigidity, a special vibration control system was developed. By reducing cycle times, this system realises high increases in productivity.

KEY BENEFITS

- Fast, flexible and powerful
- High payload: 225 kg
- Wide motion range: 2702 mm
- Maximum performance using minimal floor space

Controlled by
YRC1000

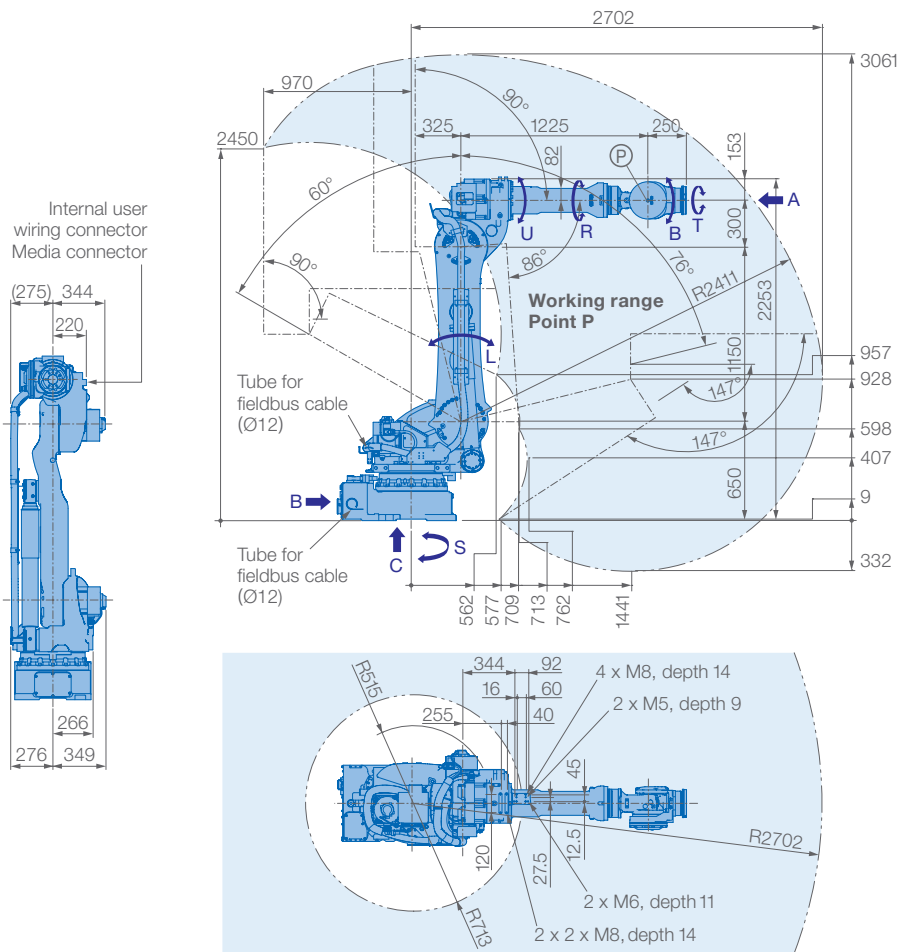

Allowable wrist load

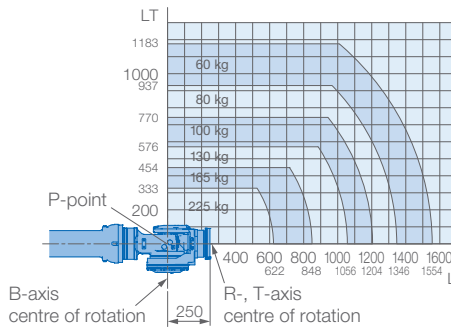

View A

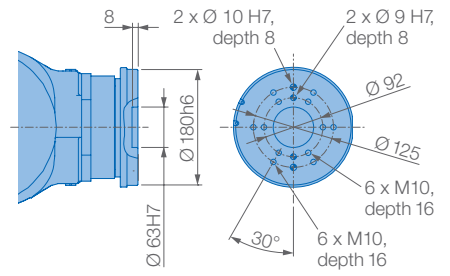

View B

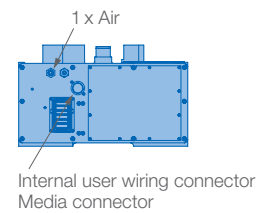

View C

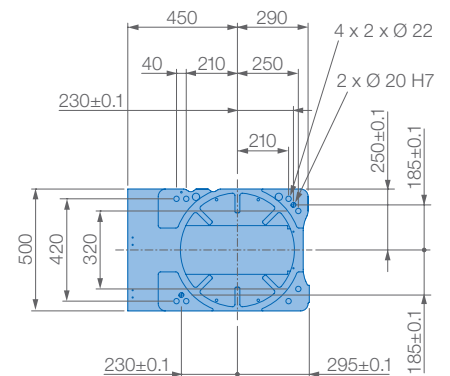

Mounting option: Floor

Protection class version YR-1-06VX225-A00
Standard: Main axes (S, L, U) IP54, wrist IP67

Protection class version YR-1-06VX225-C00:
Main axes (S, L, U) IP65, wrist IP67

Specifications GP225					
Axes	Maximum motion range [°]	Maximum speed [°/sec.]	Allowable moment [Nm]	Allowable moment of inertia [kg · m ²]	Controlled axes
S	±180	120	-	-	6
L	+76/-60	97	-	-	Max. payload [kg]
U	+90/-86	115	-	-	Repeatability [mm]
R	±360	145	1372	145	Max. working range R [mm]
B	±125	145	1372	145	Temperature [°C]
T	±360	220	735	84	Humidity [%]
					Weight [kg]
					Power supply, average [KVA]

MOTOMAN GP250

Handling & General Applications
with the GP Series



The 6-axis MOTOMAN GP250 is a versatile, high speed robot offering superior performance for a variety of applications, like material handling, machine and press tending.

Despite of providing a high payload of 250 kg and the wide motion range of 2710 mm, the MOTOMAN GP250 was designed with a width of 816 mm, therefore valuable floor space can be saved.

The vibration control system uses higher axis operation speed and speed reducer rigidity to allow fast acceleration of short movements. By reducing cycle times, this system realises high increases in productivity.

KEY BENEFITS

- Fast, flexible and powerful
- High payload: 250 kg
- Wide motion range: 2710 mm
- Maximum performance using minimal floor space

Controlled by
YRC1000

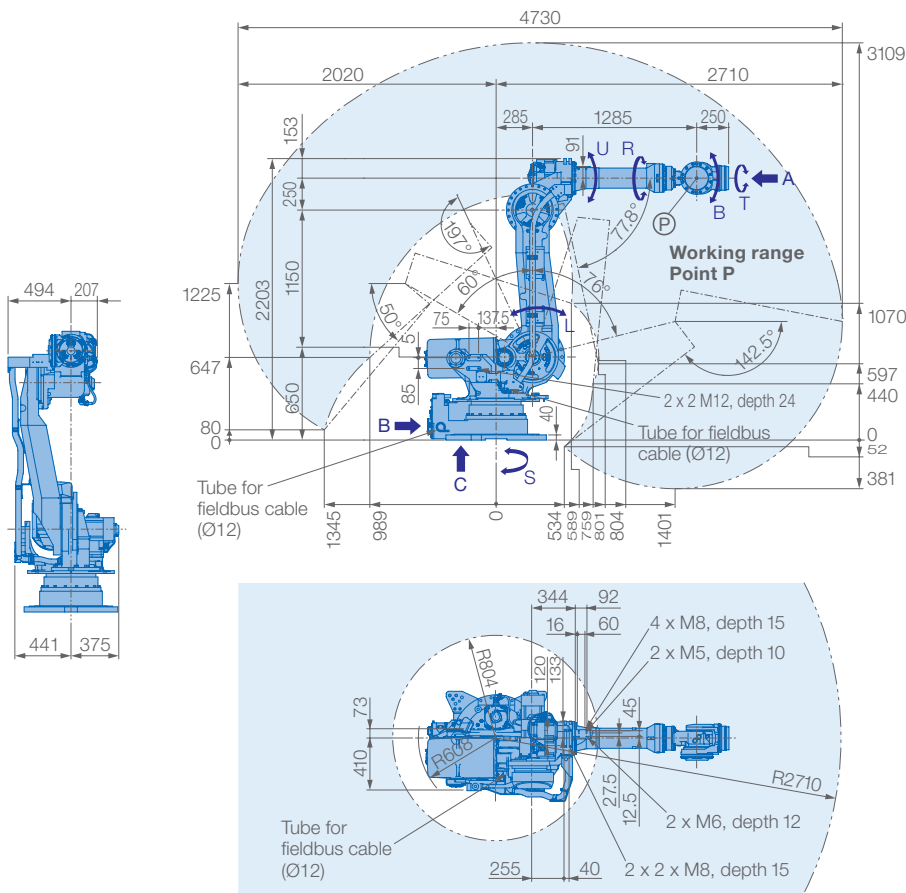

View A

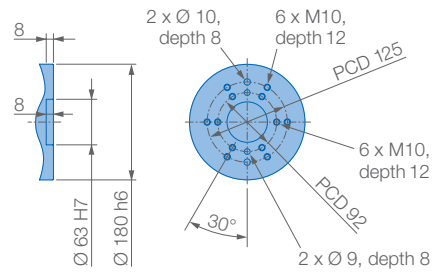

View B

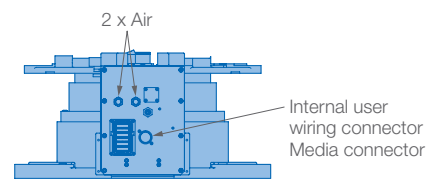

View C

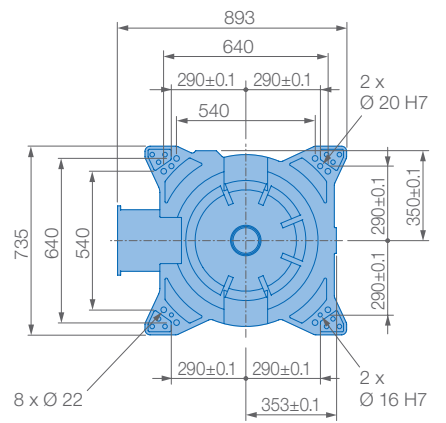

Mounting option: Floor
Protection class: IP54/IP67

Allowable wrist load

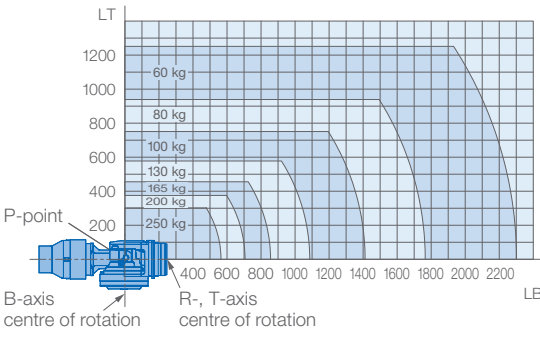

Specifications GP250						
Axes	Maximum motion range [°]	Maximum speed [°/s]	Allowable moment [Nm]	Allowable moment of inertia [kg · m ²]	Controlled axes	6
S	±180	100	-	-	Max. payload [kg]	250
L	+76/-60	90	-	-	Repeatability [mm]	±0.05
U	+197/-77.8	97	-	-	Max. working range R [mm]	2710
R	±360	120	1385	317	Temperature [°C]	0 to +45
B	±125	120	1385	317	Humidity [%]	20 - 80
T	±360	190	735	200	Weight [kg]	1345
					Power supply, average [kVA]	5.0

MOTOMAN GG250

High-Rigidity Robot for Friction Stir Welding
and Handling Applications



The MOTOMAN GG250 is a 6-axis welding robot with exceptional rigidity. With a payload of 250 kg and a reach of up to 2711 mm, this industrial robot has been specially developed for use with heavy and overhanging welding equipment for Friction Stir Welding.

Friction Stir Welding is an advanced and energy efficient welding technology that offers reduced process times, excellent weld properties and cost effectiveness.

The increased diameter of the L-arm, combined with the design-optimised S-axis, ensures that the robot retains the rigidity required for high-precision applications.

KEY BENEFITS

- Highly rigid 6-axis robot
- High payload (250 kg) and large working range (2711 mm)
- Repeatability of ± 0.025 mm
- Easy integration, commissioning and maintenance
- Supplied with +SFT instruction for simplified correction of teaching positions
- Protection class: IP54/IP65

Controlled by
YRC1000

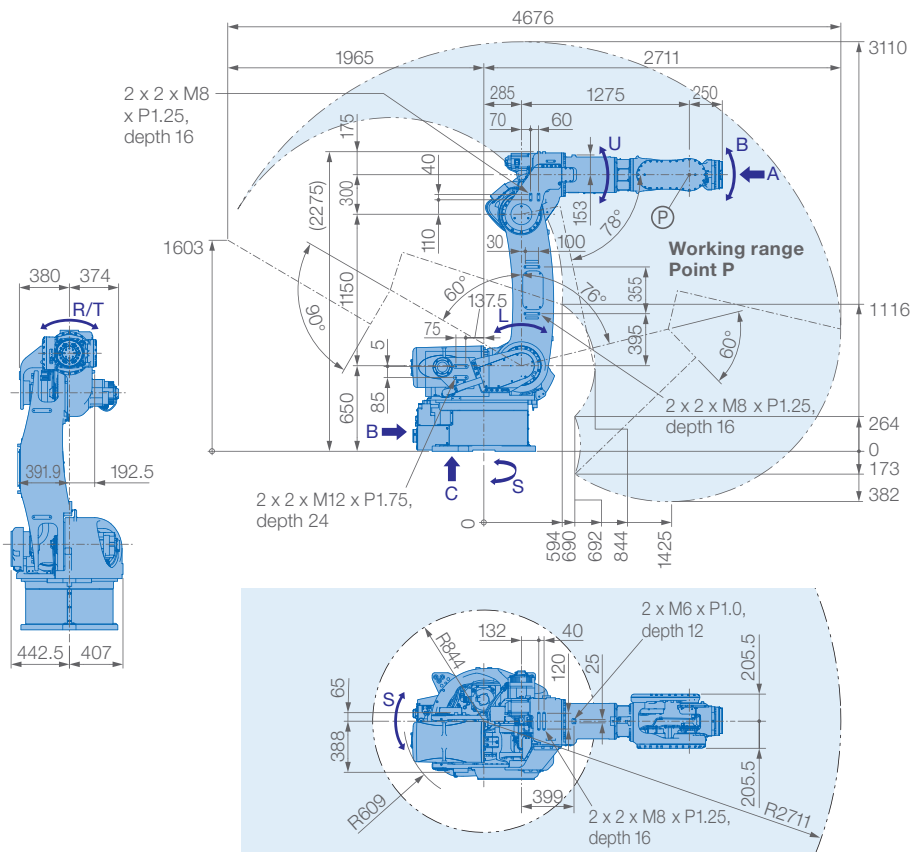

Allowable wrist load

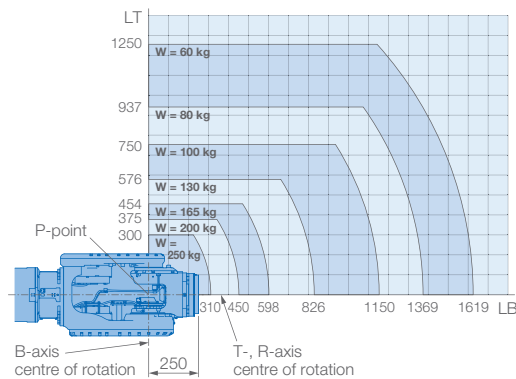

View A

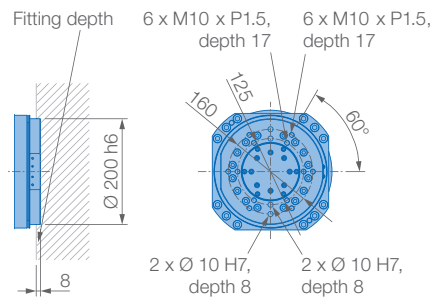

View B

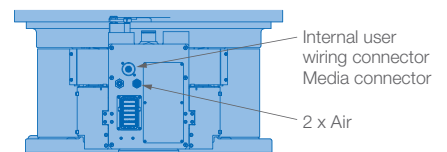

View C

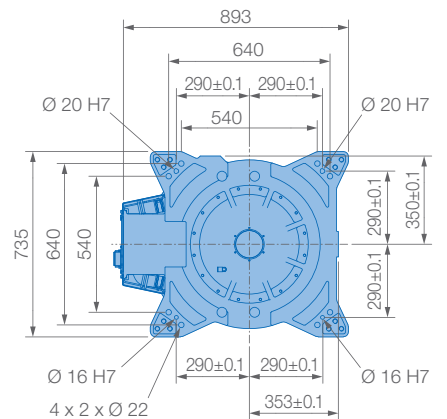

Mounting option: Floor

Protection class: IP54/IP65

Specifications GG250

Axes	Maximum motion range [°]	Maximum speed [°/sec.]	Allowable moment [Nm]	Allowable moment of inertia [kg · m ²]	Controlled axes	6
S	±180	80	-	-	Max. payload [kg]	250
L	+76/-60	75	-	-	Repeatability [mm]	±0.025
U	+90/-78	80	-	-	Max. working range R [mm]	2711
R	±210	150	1372	209.8	Temperature [°C]	0 to +45
B	±130	150	1372	209.8	Humidity [%]	20 - 80
T	±360	190	735	162.1	Weight [kg]	1640
					Power supply, average [KVA]	5.0

MOTOMAN GP280

Handling & General Applications
with the GP Series



The 6-axis MOTOMAN GP280 is a versatile, high speed robot offering superior performance for a variety of applications, like material handling, machine and press tending.

The GP280 offers a large work envelope of 2446 mm and a high moment of inertia ratings. Fast axial speeds and acceleration reduce cycle times and increase production output. The compact, slim design allows the robot to reach into confined spaces, improving system productivity.

The MOTOMAN GP280 is available with the PLd Category 3 Functional Safety Unit (FSU).

KEY BENEFITS

- Fast, flexible and powerful
- Compact design allows maximum performance using minimal floor space
- Max. payload of 280 kg
- Max. working range of 2446 mm
- Enhanced safety functions

Controlled by
YRC1000

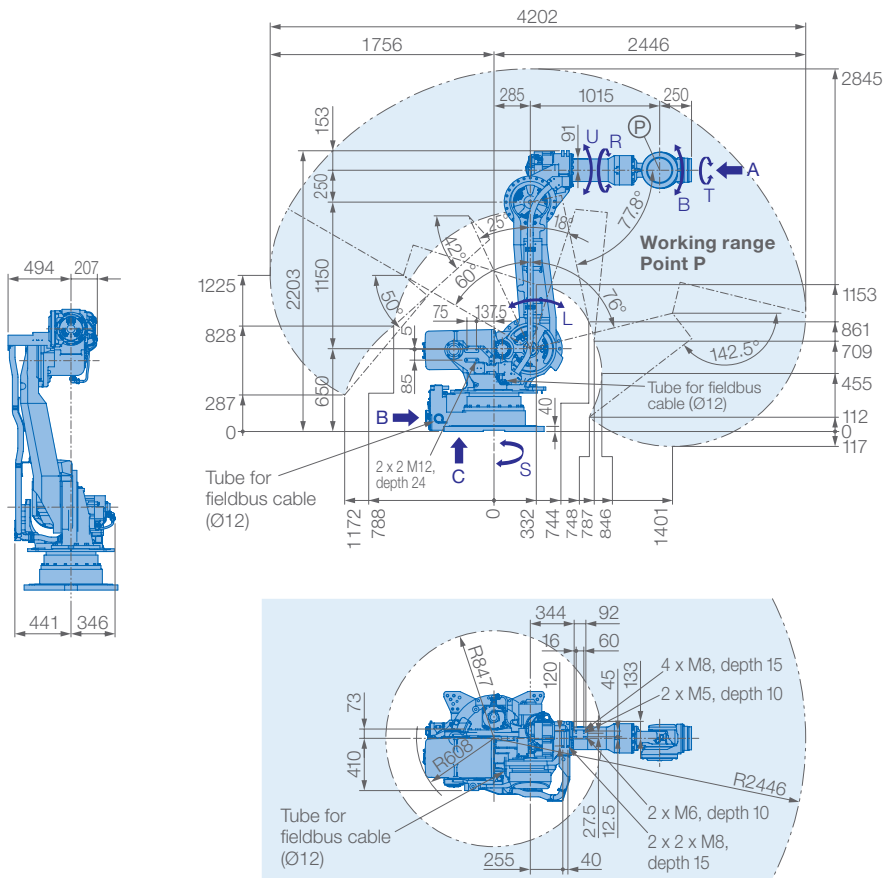

View A

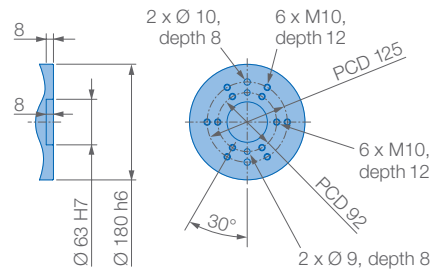

View B

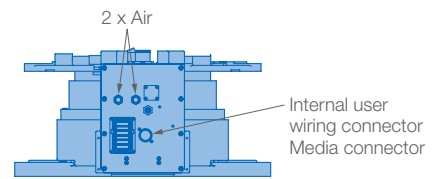

View C

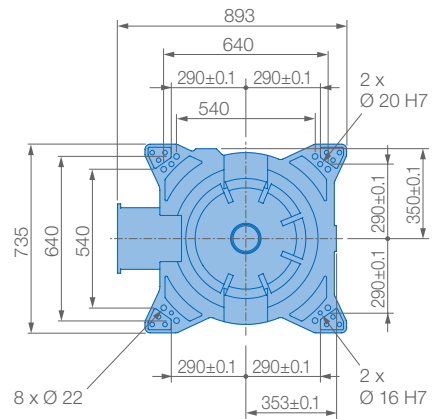

Mounting option: Floor

Protection class: IP54/IP67

Allowable wrist load

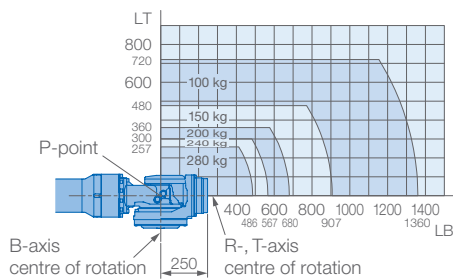

Specifications GP280						
Axes	Maximum motion range [°]	Maximum speed [°/sec.]	Allowable moment [Nm]	Allowable moment of inertia [kg · m ²]	Controlled axes	6
S	±180	90	-	-	Max. payload [kg]	280
L	+76/-60	80	-	-	Repeatability [mm]	±0.05
U	+197/-77.8	90	-	-	Max. working range R [mm]	2446
R	±360	115	1333	142	Temperature [°C]	0 to +45
B	±125	110	1333	142	Humidity [%]	20 - 80
T	±360	190	706	79	Weight [kg]	1300
					Power supply, average [KVA]	5.0

MOTOMAN GP280L

Handling & General Applications
with the GP Series



The MOTOMAN GP280L 6-axis robot is a powerful and versatile industrial robot that is ideal for a wide range of applications. The product features a high payload of 280 kg and a large working range.

The robot is an allrounder and ideal for a wide range of applications, including material handling, machine tending, assembly, and dispensing as well as palletizing tasks. It is particularly well suited for handling large workpieces, such as heavy battery modules or vehicle components in the automotive industry.

Thanks to its parallel kinematics, the robot offers high rigidity and stability when handling loads with high moments of inertia. Robust swivel bearings ensure smooth and reliable arm movement.

The GP280L is optionally available with the PLd, Category 3 »Functional Safety Unit (FSU)« for extended safety functions.

KEY BENEFITS

- Fast, flexible, and powerful
- High payload: 280 kg
- Large working range: 3,114 mm
- Parallel link design for high stability
- Heavy-duty swivel bearings for smooth arm rotation
- Advanced safety functions (PLd, Category 3 FSU available)

TYPICAL APPLICATIONS

- Material Handling
- Assembly
- Machine Tending
- Dispensing & Glueing
- Palletizing / Packaging



Controlled by
YRC1000

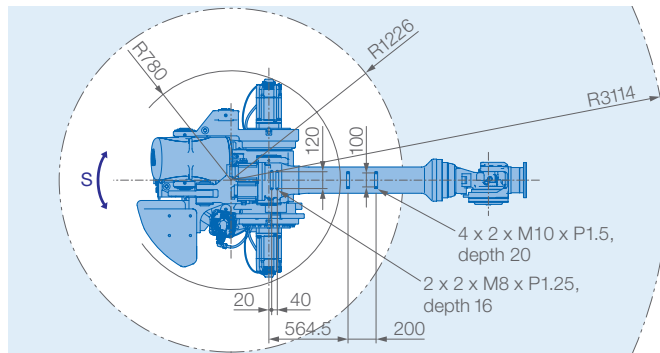
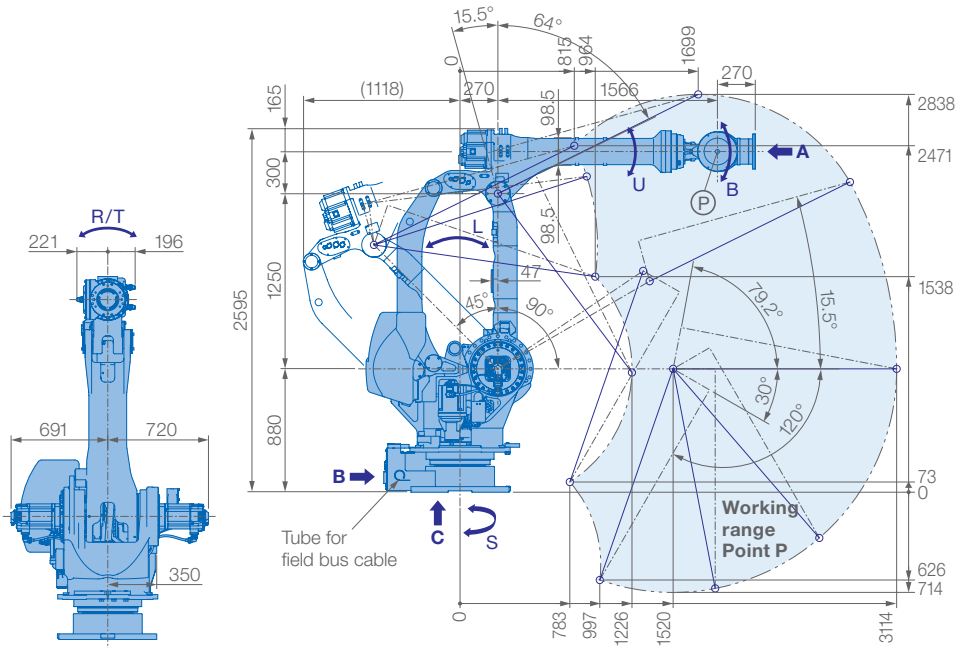

Allowable wrist load

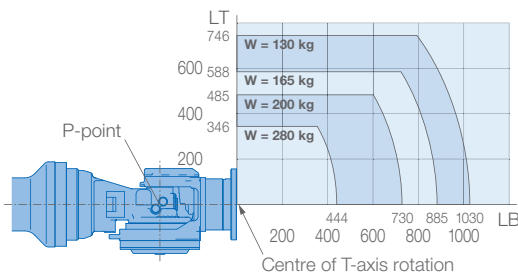

View A

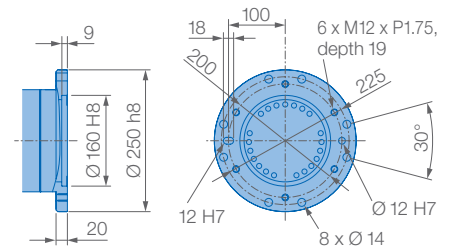

View B

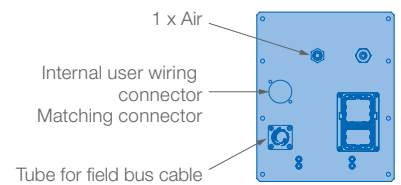

View C

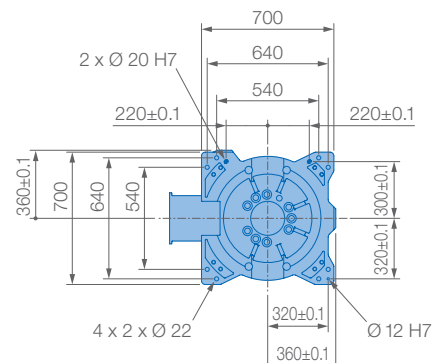

Mounting options: Floor
IP Protection: IP67 (wrist), IP54 (body)

Specifications GP280L						
Axes	Maximum motion range [°]	Maximum speed [°/s]	Allowable moment [Nm]	Allowable moment of inertia [kg · m ²]	Controlled axes	6
S	±180	110	-	-	Max. payload [kg]	280
L	+90/-45	90	-	-	Repeatability [mm]	±0.1
U	+15.5/-120	90	-	-	Max. working range R [mm]	3114
R	±360	125	1960	220	Temperature [°C]	0 to +45
B	+125	125	1960	220	Humidity [%]	20 - 80
T	±360	205	950	140	Weight [kg]	2390
					Max. connected load [kVA]	7.5

MOTOMAN GP360

Handling & General Applications
with the GP Series



The MOTOMAN GP360 6-axis robot is a powerful and versatile industrial robot that is ideal for a wide range of applications. The product features a high payload of 360 kg and a large working range.

The robot is an allrounder and ideal for a wide range of applications, including material handling, machine tending, assembly, and dispensing as well as palletizing tasks. It is particularly well suited for handling large workpieces, such as heavy battery modules or vehicle components in the automotive industry.

Thanks to its parallel kinematics, the robot offers high rigidity and stability when handling loads with high moments of inertia. Robust swivel bearings ensure smooth and reliable arm movement.

The GP360 is optionally available with the PLd, Category 3 »Functional Safety Unit (FSU)« for extended safety functions.

KEY BENEFITS

- Fast, flexible, and powerful
- High payload: 360 kg
- Large working range: 2,832 mm
- Parallel link design for high stability
- Heavy-duty swivel bearings for smooth arm rotation
- Advanced safety functions (PLd, Category 3 FSU available)

TYPICAL APPLICATIONS

- Material Handling
- Assembly
- Machine Tending
- Dispensing & Glueing
- Palletizing / Packaging



Controlled by
YRC1000

MOTOMAN GP400

Handling & General Applications
with the GP Series

The 6-axis MOTOMAN GP400 is a versatile, powerful robot offering superior performance for a variety of applications. It provides a high payload of 400 kg and a wide motion range, which especially enables the handling of large work pieces.

The robot features a parallel-link construction for strength, rigidity and stabilization of high moment and inertia loads. The GP400 also has heavy-duty bearings which provide a smooth arm rotation.

The MOTOMAN GP400 is available with the PLd Category 3 Functional Safety Unit (FSU).

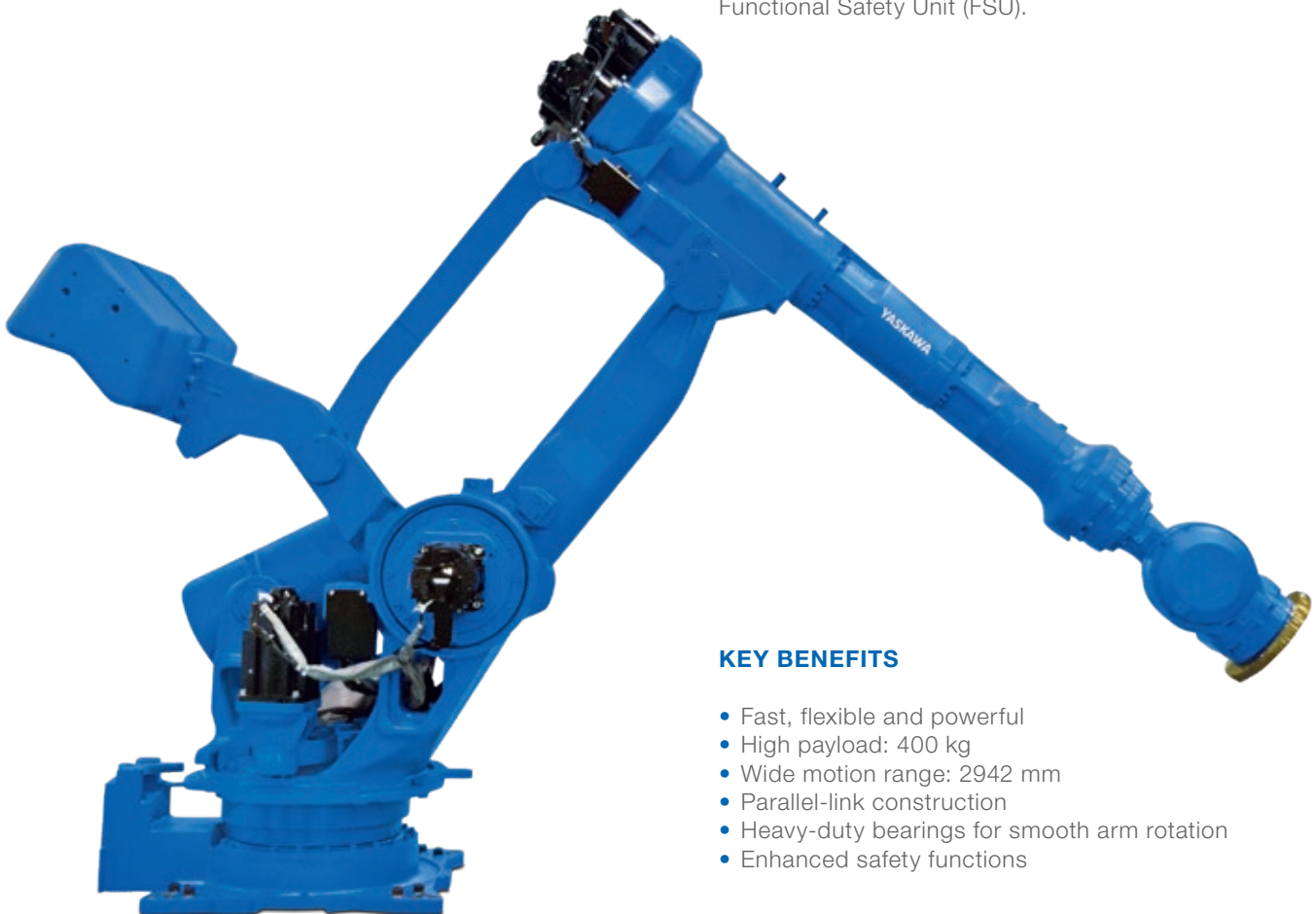

KEY BENEFITS

- Fast, flexible and powerful
- High payload: 400 kg
- Wide motion range: 2942 mm
- Parallel-link construction
- Heavy-duty bearings for smooth arm rotation
- Enhanced safety functions

Controlled by
YRC1000

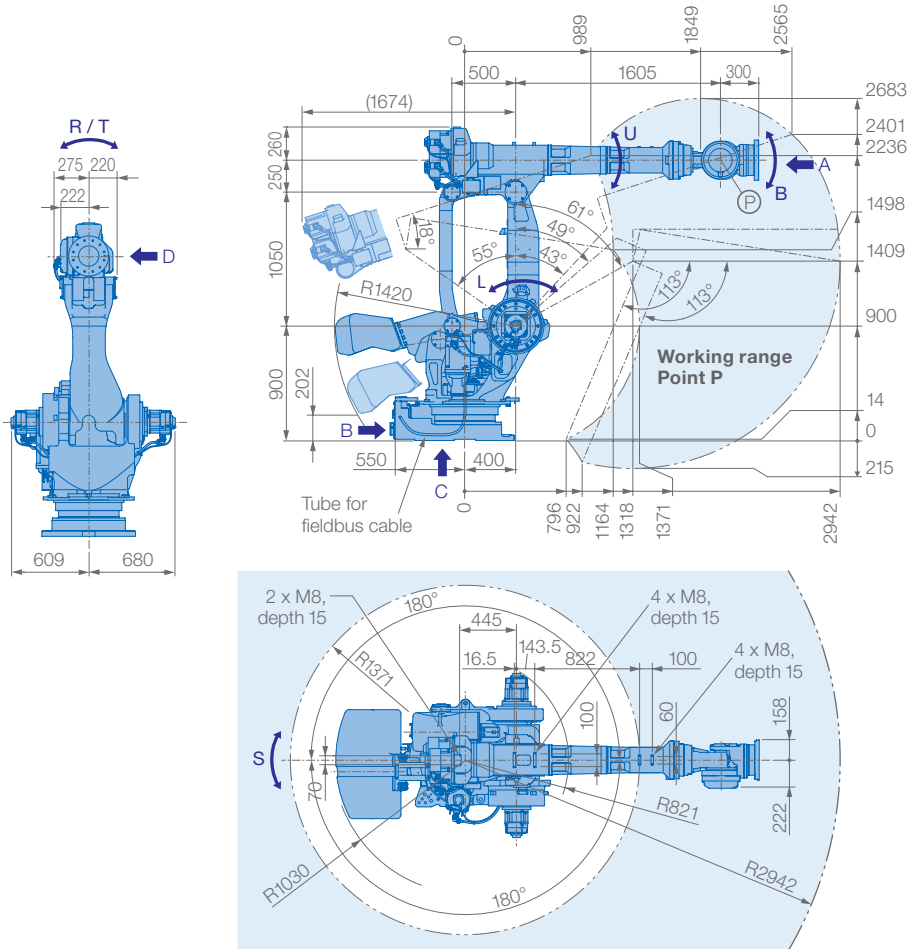

View A

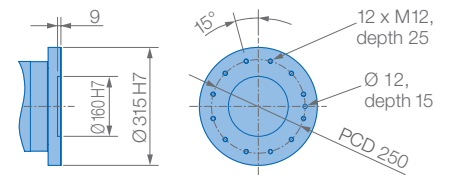

View B

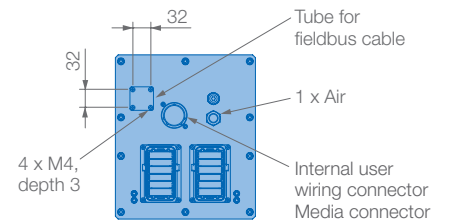

View C

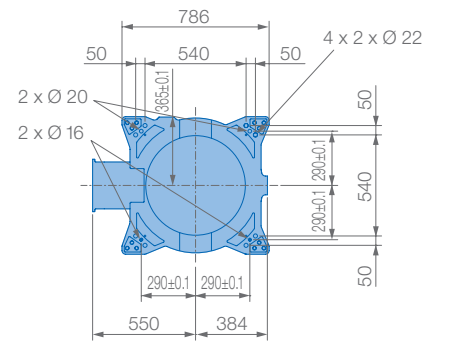

Mounting option: Floor
Protection class: IP30/IP67

View D

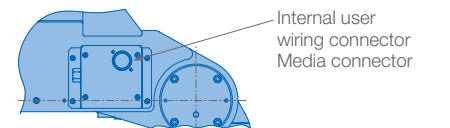

Allowable wrist load

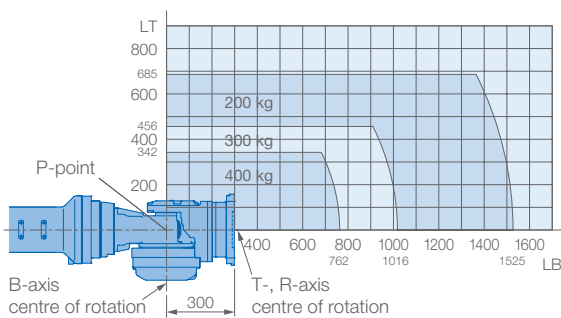

Specifications GP400						
Axes	Maximum motion range [°]	Maximum speed [°/sec.]	Allowable moment [Nm]	Allowable moment of inertia [kg · m ²]	Controlled axes	6
S	±180	102	-	-	Max. payload [kg]	400
L	+61/-55	97	-	-	Repeatability [mm]	±0.1
U	+18/-113	97	-	-	Max. working range R [mm]	2942
R	±360	80	2989	500	Temperature [°C]	0 to +45
B	±115	80	2989	500	Humidity [%]	20 - 80
T	±360	172	1343	315	Weight [kg]	2840
					Power supply, average [KVA]	7.0

MOTOMAN GP600

Handling & General Applications with the GP Series

The 6-axis MOTOMAN GP600 is a versatile, powerful robot offering superior performance for a variety of applications. It provides a high payload of 600 kg and a wide motion range, which especially enables the handling of large and heavy work pieces.

The robot features a parallel-link construction for strength, rigidity and stabilization of high moment and inertia loads. The GP600 also has heavy-duty bearings which provide a smooth arm rotation.

The MOTOMAN GP600 is available with the PLd Category 3 Functional Safety Unit (FSU).

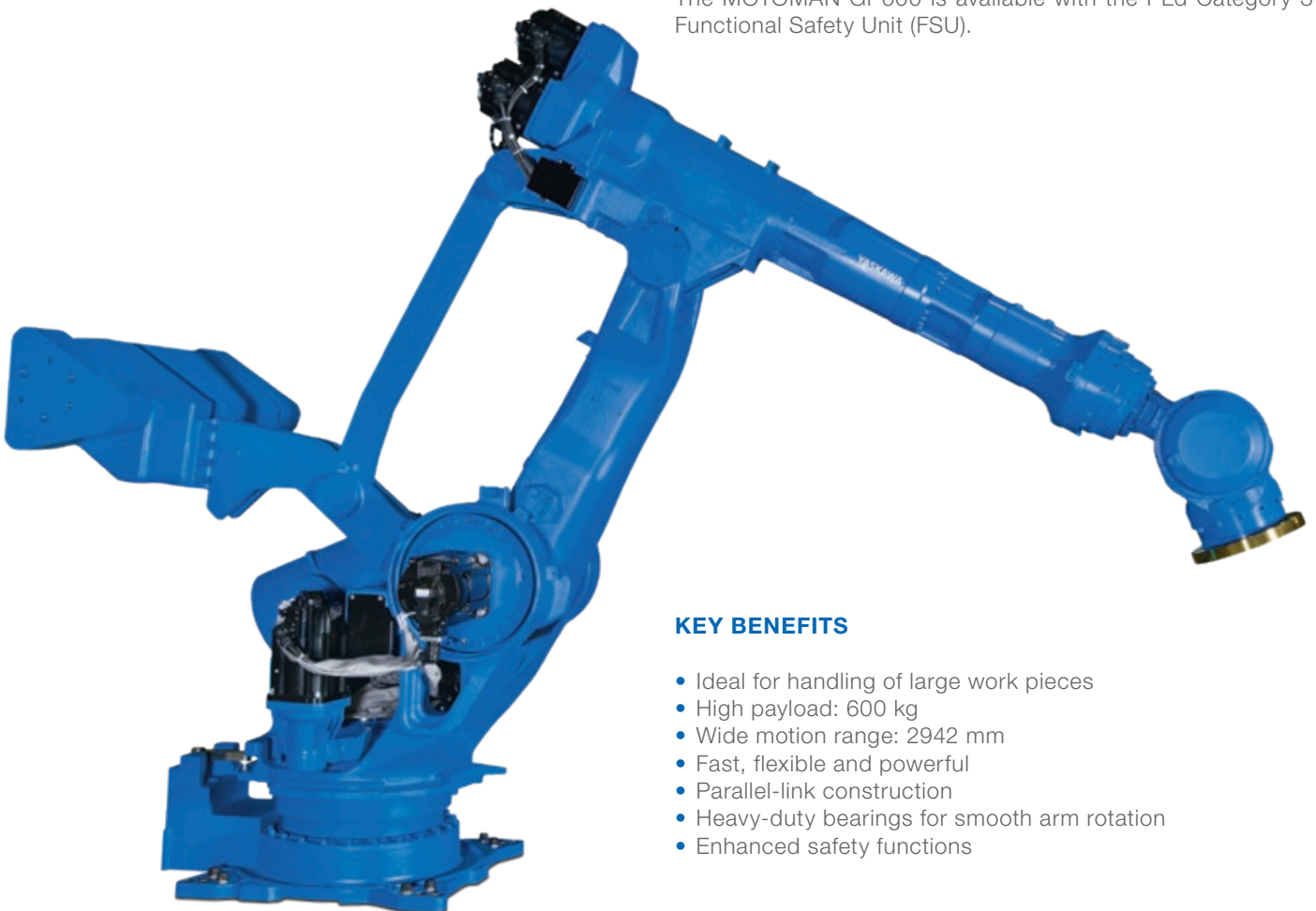

KEY BENEFITS

- Ideal for handling of large work pieces
- High payload: 600 kg
- Wide motion range: 2942 mm
- Fast, flexible and powerful
- Parallel-link construction
- Heavy-duty bearings for smooth arm rotation
- Enhanced safety functions

Controlled by
YRC1000

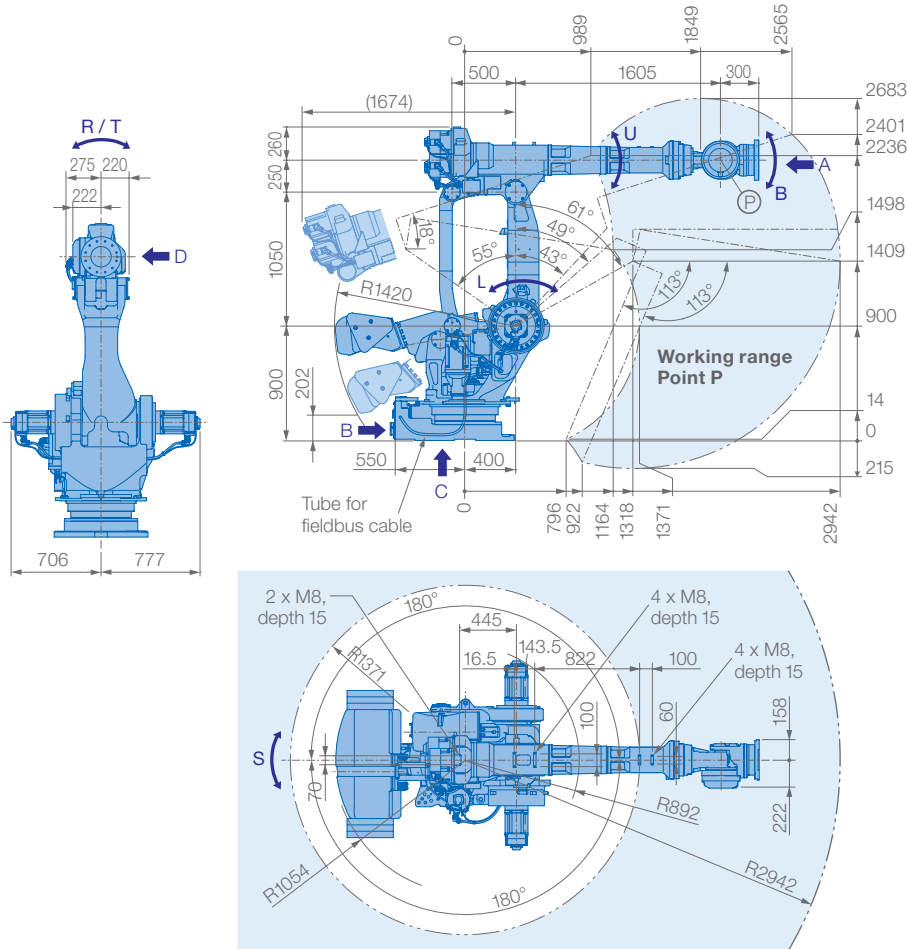

View A

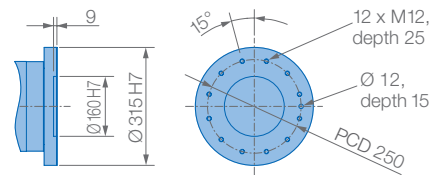

View B

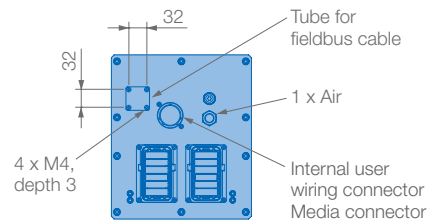

View C

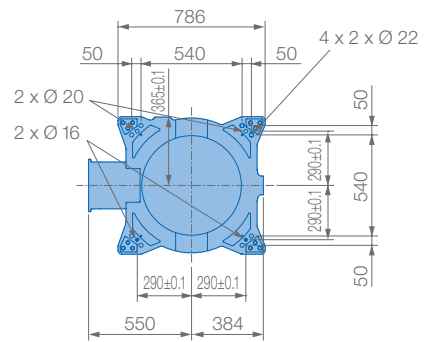

Mounting option: Floor
Protection class: IP30/67

View D

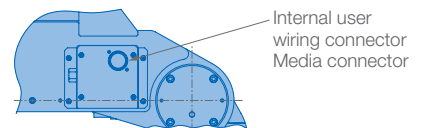

Allowable wrist load

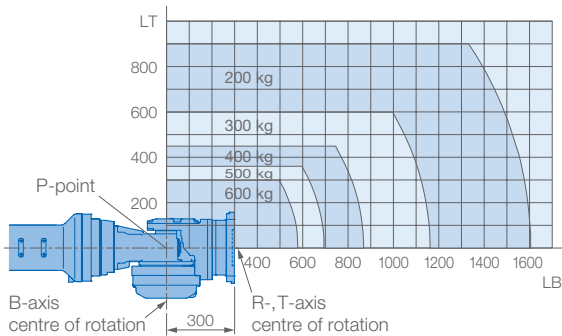

Specifications GP600

Axes	Maximum motion range [°]	Maximum speed [°/sec.]	Allowable moment [Nm]	Allowable moment of inertia [kg · m ²]	Controlled axes	6
S	±180	82	-	-	Max. payload [kg]	600
L	+61/-55	82	-	-	Repeatability [mm]	±0.1
U	+18/-113	82	-	-	Max. working range R [mm]	2942
R	±360	80	3430	520	Temperature [°C]	0 to +45
B	±115	80	3430	520	Humidity [%]	20 - 80
T	±360	162	1764	350	Weight [kg]	3035
					Power supply, average [KVA]	7.0

YASKAWA

B

T

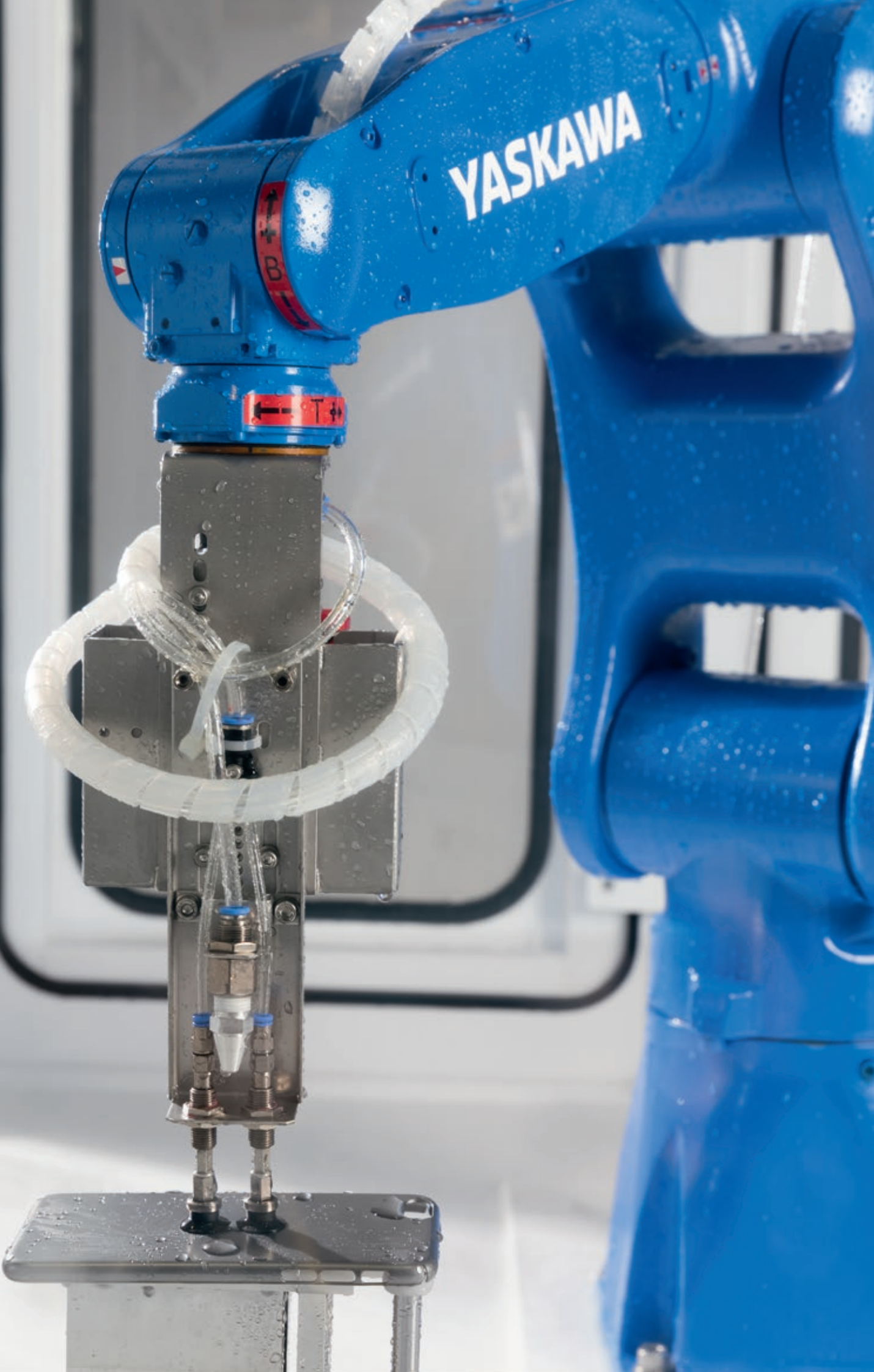



JOB EDIT DISPLAY UTILITY S:0000
TOOL: **

JOB CONTENT
J:T-ACHSE
CONTROL GROUP: R1

```
0000 NCP  
0001 0001 00 MOVJ VJ=100.00  
0002 TIMER T=1.00  
0003 0002 00 MOVJ VJ=100.00  
0004 END
```

MOVJ VJ=20.00

Main Menu Simple Menu

YASKAWA

MOTOMAN YRC1000

Industrial Robot Controller



High Performance Controller YRC1000 for MOTOMAN Robots

The MOTOMAN YRC1000 is a compact, fast and flexible controller for MOTOMAN robots that combines high performance robot control in a small footprint cabinet with volume of 125 litres and a maximum weight of 70 kg.

Besides the typical Yaskawa controller functionality, the YRC1000 includes additional functional improvements. Speed of the controller has been increased by lowering a ladder scanning time.

Path accuracy improvement assures increased precision in trajectory performance independently on the motion speed.

User interface supports smartphone like touch operations and allows the user to 3D simulate robots motion on PP screen before and during execution of the real robot arm. Service staff can directly connect to the PP user interface for remote service purposes. Total programming pendant's weight was reduced to 730 grams which offers more convenient use by the operator. The new controller simplifies maintenance by offering preventive maintenance information and powerful software tools for analysis and notification.

KEY BENEFITS

- Compact, fast and flexible
- Global standardization (no transformer required)
- High path accuracy
- High efficiency

Optimal Industrial Design

- Volume: 125 liters



Programming Pendant (PHG) – ergonomical, light and easy

5.7" LCD colour display
Touch screen
Option: Windows operating system

Operation keys start/stop emergency off

USB-Connection and SD-card slot (reverse side)

Cursor key

Main axes keys

Additional axes keys

3 position dead man switch in compliance with DIN EN ISO 10218-1

Display can be individually set for applications:
– Shielded Arc Welding
– Spot Welding
– General Applications

- Easy and fast programming
- Several user levels – from operator to safety mode
- Help function



Specifications controller YRC1000	
Dimensions	598 (W) x 490 (H) x 427 (D) mm (125 l without protrusion parts)
Weight	70 kg max. (possible to control three external axes)
Protection class	IP54
Cooling system	Indirect cooling
Ambient temperature	During operation: 0°C to +45°C / During storage: -10°C to +60°C
Relative humidity	90 % max. (non-condensing)
Power supply	Three-phase 380–440 VAC (+10 %, -15 %), 50/60 Hz (±2 %)
Digital I/Os	Specialized signals: 19 inputs and 6 outputs / General signals: 40 inputs and 40 outputs
Programming capacity	JOB: 200,000 steps, 10,000 instructions / CIO ladder: 20,000 steps
Expansion slots	2 x PCIe or 2 x PCI or 1 x PCI/1 x PCIe
LAN (Connection to host)	2 (10BASE-T/100BASE-TX)
Interface	RS-232C/RS422: 1 ch (used by switching)

Common Size for use
in Japan, Asia, Europe, and the U.S.



Improved Programming Pendant



Specifications programming pendant	
Dimensions	152 (W) x 299 (H) x 53 (D) mm
Weight	0.730 kg
Material	Reinforced plastics
Operation device	Select keys, axis keys, numerical/application keys, mode selector switch with keys (mode: teach, play, and remote), emergency stop button, enable switch, SD card interface device, USB port (1 port)
Display	5.7-inch color LCD, touch panel 640 x 480 pixels
IEC protection class	IP54



MOTOMAN YRC1000micro

Industrial Robot Controller
for small MOTOMAN Robots

The MOTOMAN YRC1000micro controller is a controller for small MOTOMAN robots. It provides high performance robot control in a small footprint cabinet. Its performance and functions are optimized for Pick & Place and assembly applications.

Besides the typical Yaskawa functionality, the MOTOMAN YRC1000micro controller includes easy connections to peripheral devices and new high speed and high precision motion control.

It is compatible with the optional "Functional Safety", which monitors motion range and speed limitations.



KEY BENEFITS

- Compact and lightweight
- High performance
- New motion control
- Minimum installation space
- Easy connections to peripheral devices
- Compatible with "Functional Safety"

Industrial Robot Controller

YRC1000micro

for small MOTOMAN Robots

Specifications Controller YRC1000micro	
Configuration	Open structure
Dimensions	425 (W) x 125 (H) x 280 (D) mm – excluding protrusions
Weight	10.5 kg (without top mount box)
Protection class	IP20
Cooling system	Direct cooling
Ambient temperature	During operation: 0°C to +40°C During storage: -10°C to +60°C
Relative humidity	90 % max. (non-condensing)
Power supply	Single-phase 200/230 VAC (+10 to -15%), 50/60 Hz (± 2 %) ¹ ; three-phase 220/220 VAC (+10 to -15 %), 50/60 Hz (± 2%)
Digital I/Os	External IO (hardware, standard max): 8 inputs / 8 outputs (transistor 100 mA) ² Standard signal allocation: General Purpose IO: 1 input / 1 output Specific IO: 7 inputs / 7 outputs
Programming capacity	JOB: 200,000 steps, 10,000 instructions; CIO ladder: 1,500 steps
Expansion slots	PCI express, 2 slots
LAN (Connections to host)	1 (10BASE-T/100BASE-TX)
Safety category	4, PLd

¹ Manipulators operated by single-phase power supply: MOTOMAN GP7, GP8, MotoMINI.

² If it is necessary to expand the number of points, a filed bus board is required

Specifications programming pendant	
Dimensions	152 (W) x 299 (H) x 53 (D) mm
Weight	0.730 kg
Material	Reinforced plastics
Operation device	Select keys, axis keys, numerical/application keys, mode selector switch with keys (mode: teach, play, and remote), emergency stop button, enable switch, SD card interface device, USB port (1 port)
Display	5.7-inch color LCD, touch panel 640 x 480 pixels
IEC Protection class	IP54

Programming Pendant (PHG) – ergonomical, light and easy



Horizontally mounted ***

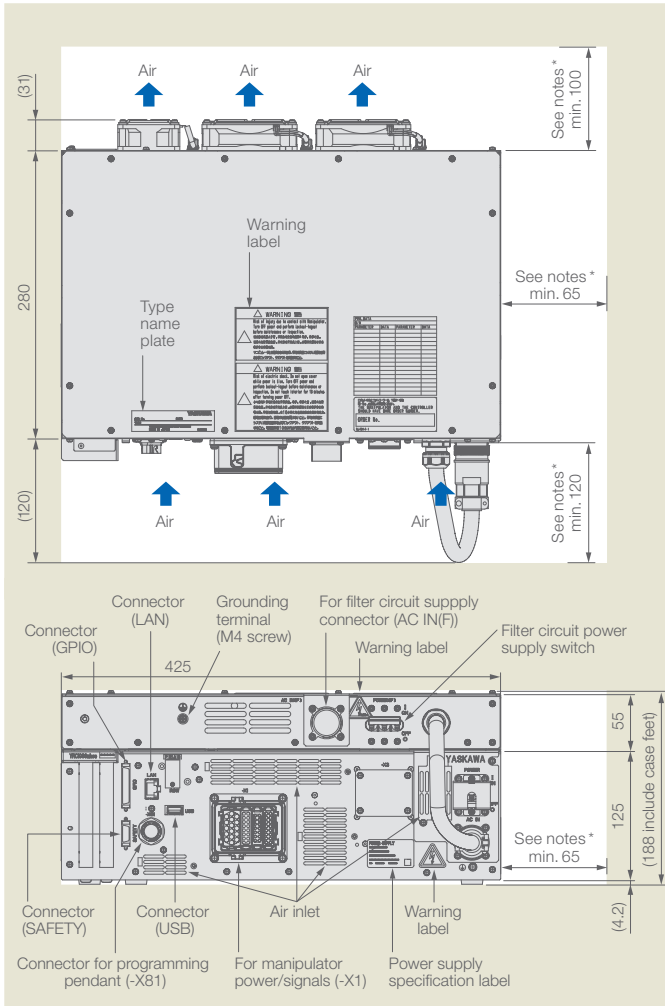

Optimal Industrial Design

- Volume: 21.5 l (GP7/8/12, MotoMini), 33.5 l (HC10DT)

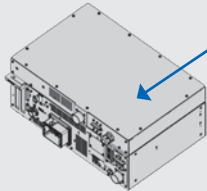
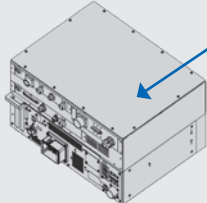

Manipulator type		Region: Europa and Korea (EMC directive required)
Standard size: 425 (W) x 125 (H) x 280 (D) mm	GP7 GP8 GP12 MotoMINI	 <p>Top mount box for CE noise filter: 55 (H) x 280 (D) mm</p> <p>Total litres: 21.5 l</p>
without additional boxes		
without EMV	HC10	 <p>Top mount box for CE noise filter PFL-Card: 125 (H) x 280 (D) mm</p> <p>Total litres: 33.5 l</p>

Vertically mounted ***

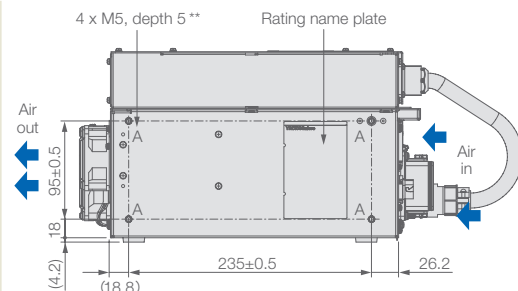
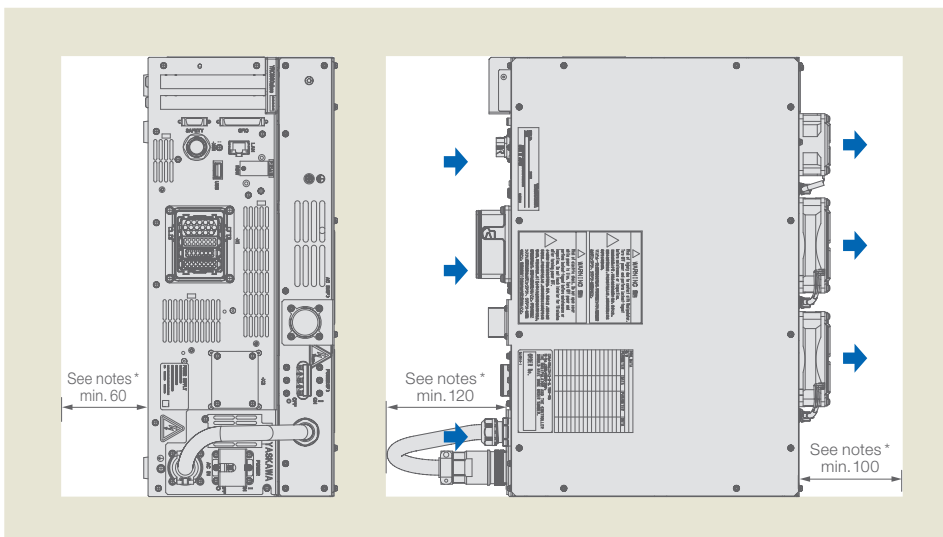

* Secure the dimensions stated in the placement space chart for cooling and maintenance.
 ** Use eight holes marked with the symbol "A" to fix the controller on the floor with fixing jigs and anchor bolts. When fixing the rack, use A hole (8 places).
 *** Values refer to version for GP7, GP8, GP12 und MotoMini).



MOTOMAN GP8



reddot award 2018
winner



Smart Pendant

Quick and easy programming



The Yaskawa Smart Pendant is an innovative teach pendant with a large 10-inch touch screen and offers a newly thought-out operator control concept.

The tablet-based graphical user interface (GUI) enables the guided entry of commands, parameters, functions and program sequences. The central interface comprises the main and navigation menus, where entries are listed and switched in a specific, easily comprehensible order.

The Smart Pendant has a revolutionary patented coordinate system – the “Smart Frame” – that also supports rotation and inclination of the Smart Pendant. This means that the operator no longer has to convert motions or break them down into a coordinate space (X,Y,Z) when teaching them, and his line of vision relative to the robot is automatically taken into consideration by the system.

In the case of collaborative robots, the “Hand Guiding” function – guiding the robot manually to a desired position – is also supported.

The Smart Pendant is available for the following MOTOMAN robots with the YRC1000 and YRC1000micro controller generations:

- **MOTOMAN YRC1000:**
HC10, HC10DT, HC20DT, GP7 to GP600
- **MOTOMAN YRC1000micro:**
MotoMINI, HC10DT, HC20DT, GP7, GP8, GP12

KEY BENEFITS

- Large touch screen (10")
- Ergonomic design with low weight, diagonal side cable entry and integrated Emergency Stop
- Simple and intuitive operator control, short learning curve
- Ideal for users who need to carry out frequent reprogramming and thus appreciate simple operator control
- Supports many powerful functions of the MOTOMAN YRC1000
- Context-sensitive help and help menu offer many explanations

YRC1000

YRC1000
micro

Smart Pendant

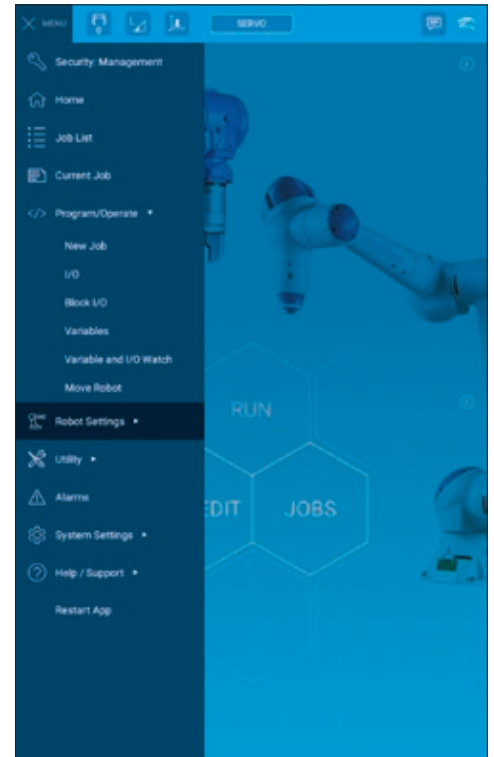

Main menu

Smart Frame

The patented technology of the “Smart Frame” determines the user’s orientation relative to the robot. This eliminates the use of conventional coordinates (X, Y, Z) frames. The intuitive robot jogging by tilting the smart pendant makes it also easy to use.



Simplified Programming

Command Builder function enables various editing possibilities.

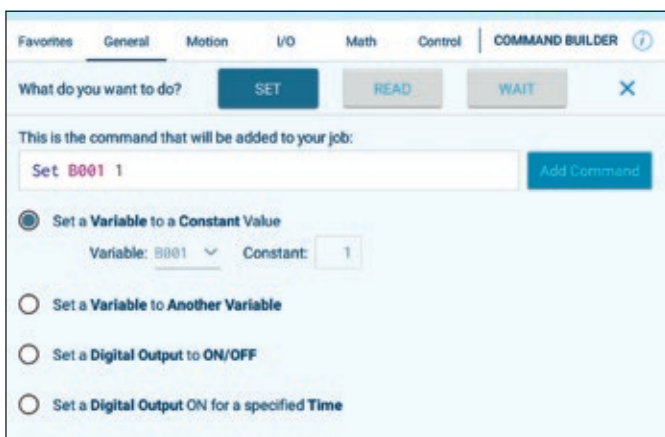

Configuration enables fast TCP setup

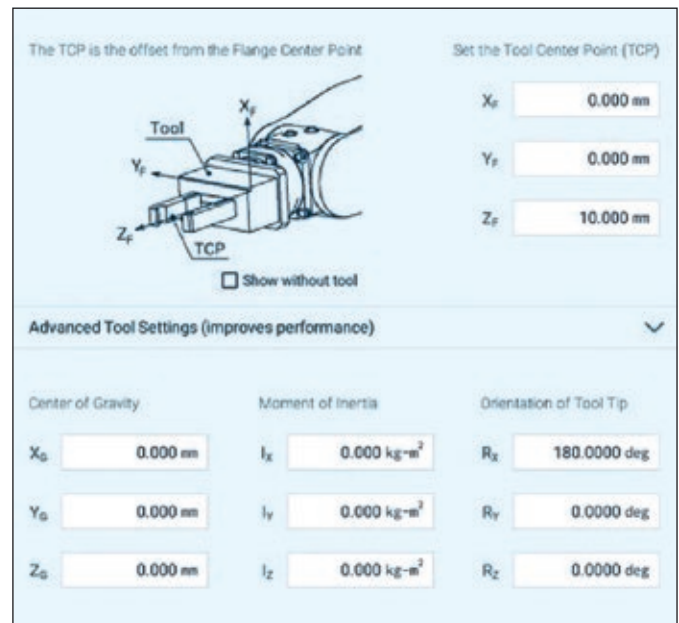

Simple tool

Hand Guiding

This function enables manual guidance of the robot to a desired position by hand.

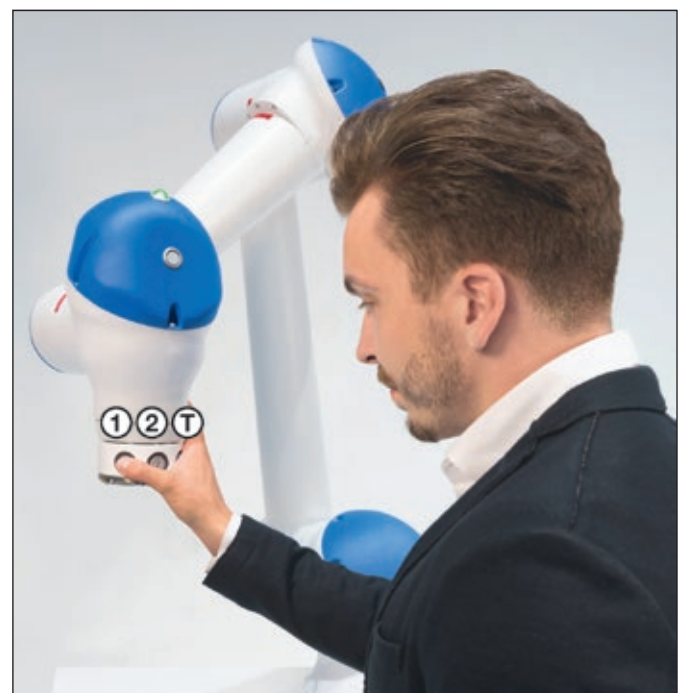
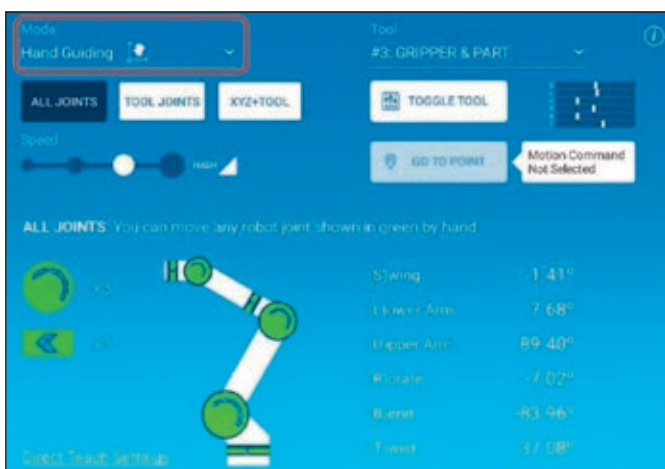

- ① Button replaces deadman switch
- ② Button is freely programmable (i.e. Open/Close gripper)
- Ⓣ Teach button to program current position

Optimize your energy consumption by recovering braking energy

Yaskawa offers a technical solution for feeding robot braking energy back into the in-house power supply system – as standard and without additional hardware. All larger MOTOMAN robots with payloads of 35 kg or more and the current YRC1000 robot controller are able to convert kinetic energy from downward and sideways motions directly into the power supply system. Depending on the motion profile, this considerably reduces the energy requirements of the robot.

How does energy recovery work in practice?

In their varied tasks – such as handling, palletizing or machine tending – industrial robots perform many downwards or sideways motions during which the servomotors dissipate energy and can possibly generate current. Until now, in older robots or other robot models on the market, the energy has been transformed into waste heat by electrical resistors and dissipated unused into the environment.

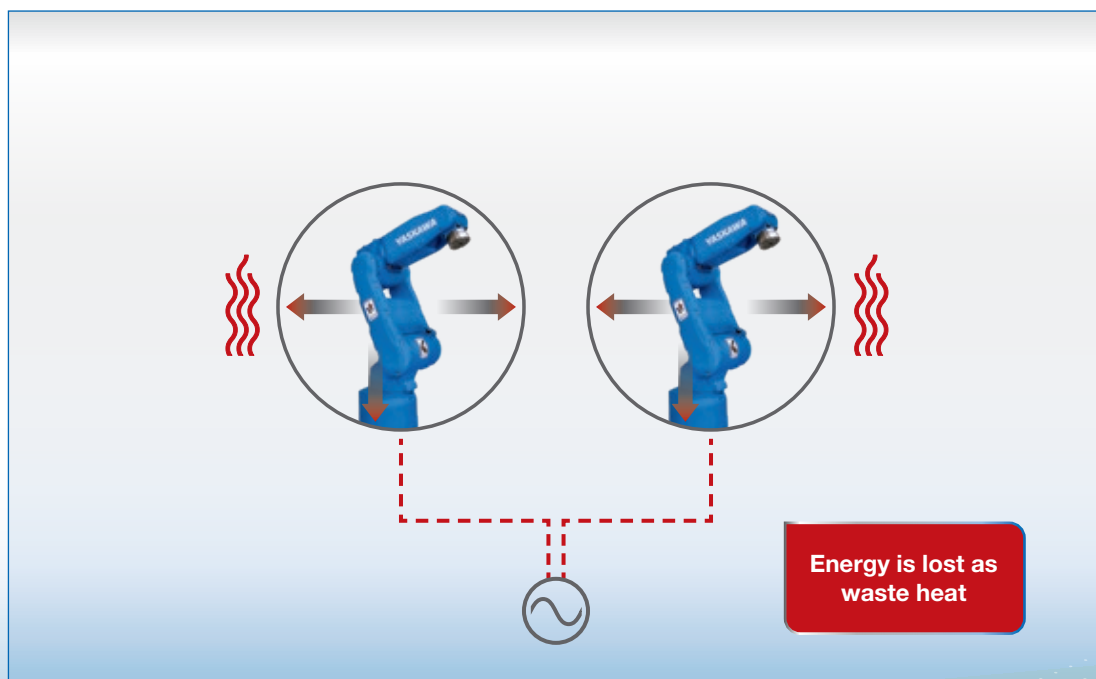

The solution from Yaskawa feeds the electrical energy back into the in-house power supply system of the user and reuses it without the need for additional hardware. All MOTOMAN robots with a payload capacity of approx. 35 kg or higher and the current YRC1000 robot controller are able to convert kinetic energy from downward and sideways motions directly into 400 VAC with 50 Hz and feed it back into the in-house power supply system. This is also possible with external axes of the robot. Depending on the motion profile, the energy requirements of the robot are thus considerably reduced.

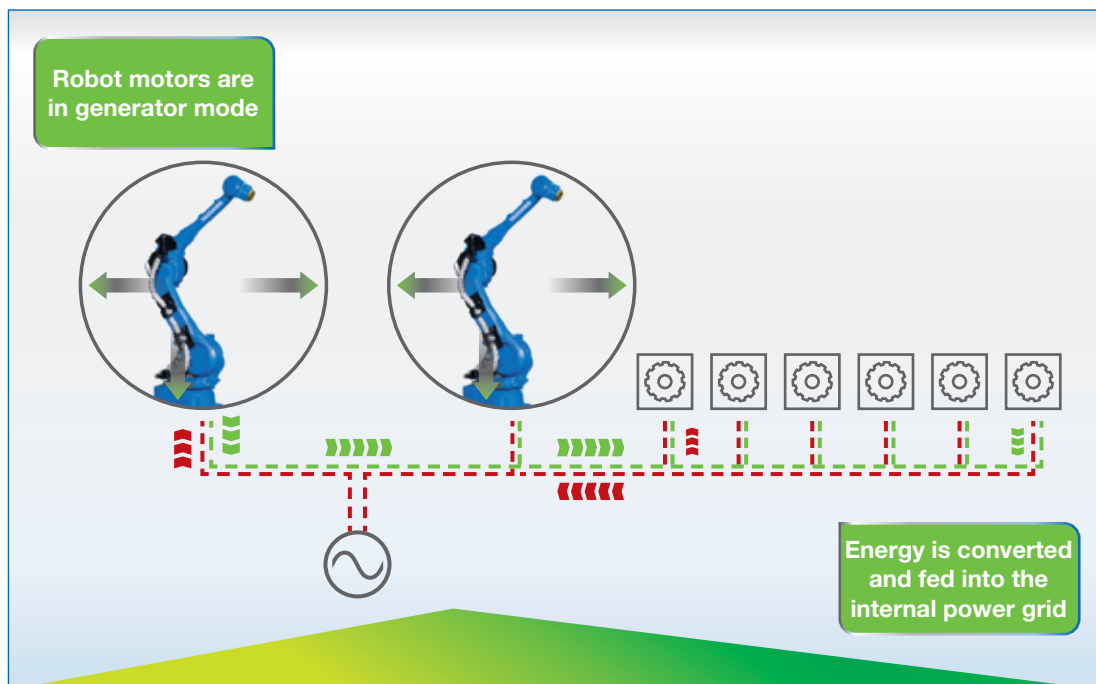

The specific savings depend on the task and the individual motion profile of the robot. They can vary between 8% and 25%. The energy saved has a positive effect on the CO₂ balance.

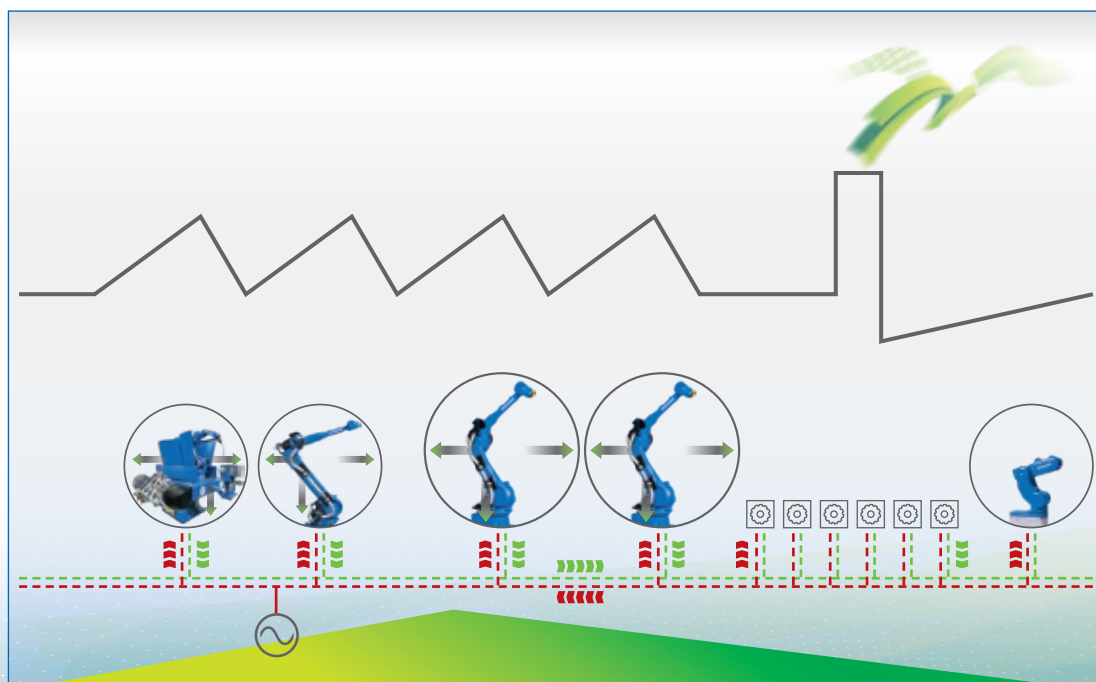

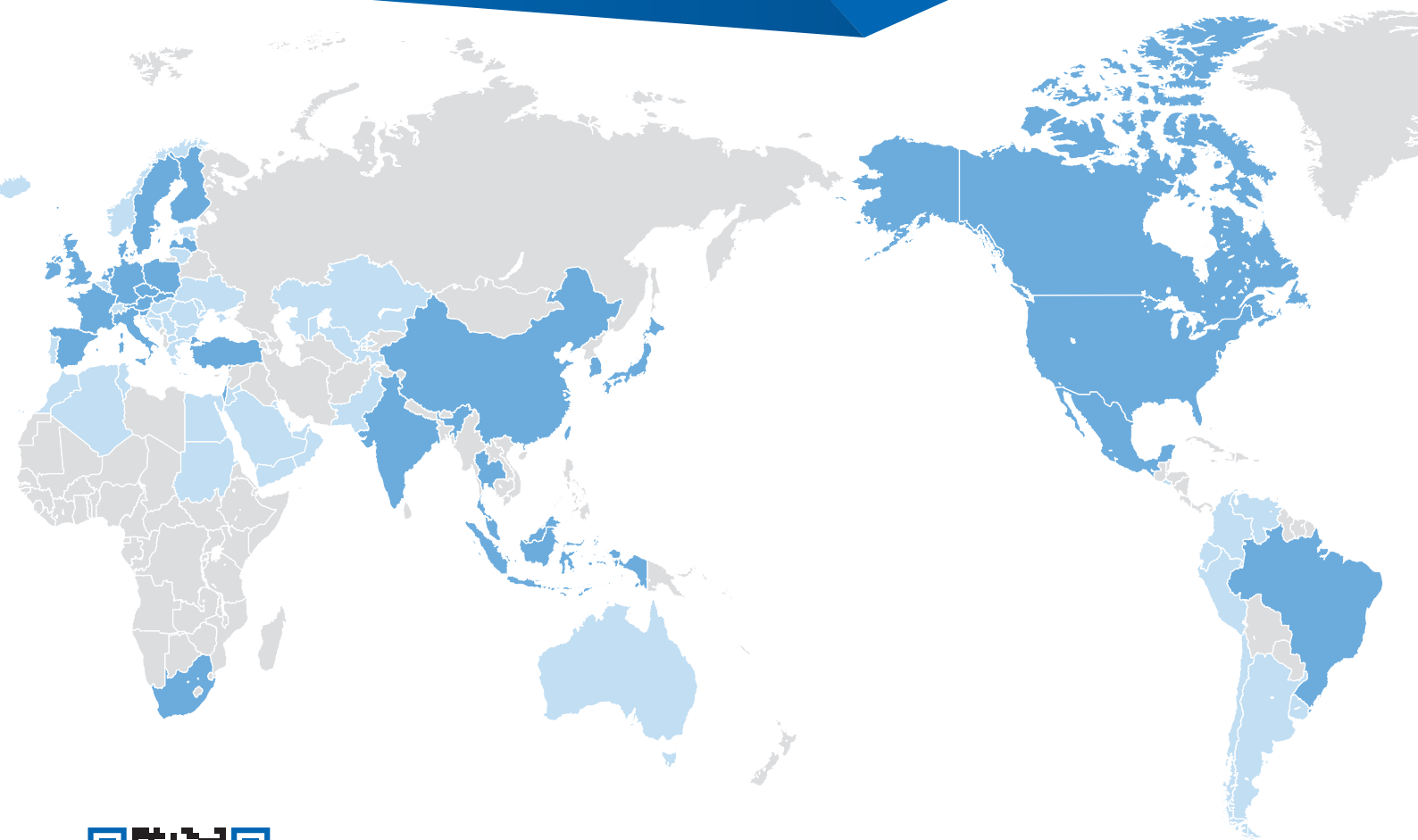

Robotics Division

YASKAWA Europe GmbH
Yaskawastraße 1
85391 Allershausen, Germany
Tel. +49 (0) 8166/90-0
Fax +49 (0) 8166/90-103

**YASKAWA Headquarters
Academy and Sales Office**

YASKAWA Europe GmbH
Philipp-Reis-Straße 6
65795 Hattersheim am Main, Germany
Tel. +49 (0) 6196/77725-0
Fax +49 (0) 6196/77725-39

All drawing dimensions in mm.
Technical data may be subject to change without previous notice.
Please request detailed drawings at robotics@yaskawa.eu.

GP Series
L-03-2026, A-No. 180894

robotics@yaskawa.eu
www.yaskawa.eu

YASKAWA